

Maxi Sky 440



For Internal Use Only

Design Policy and Copyright

® and ™ are trademarks belonging to the Arjo group of companies.
© Arjo 2019.

As our policy is one of continuous improvement, we reserve the right to modify designs without prior notice.
The content of this publication may not be copied either whole or in part without the consent of Arjo.

Table of Contents

Safety Instructions	1
Warnings	1
Equipment Identification	1
Shock Prevention	1
Fire and Explosion Prevention.....	1
Safe Working Load.....	1
Updating Instructions	1
Product Description	3
<i>Hand Control Replacement</i>	4
Service Procedures	4
<i>Bottom Plastic Cover Replacement</i>	4
<i>Main Plastic Cover Replacement</i>	5
<i>Batteries Replacement</i>	6
<i>Fuse Replacement</i>	7
<i>Pass Through Hook Replacement</i>	7
<i>Strap Inlet Replacement</i>	7
<i>Folding Arm Replacement</i>	8
<i>Hand Control and Charger Interface Circuit</i>	9
<i>Main Circuit Board Replacement</i>	9
<i>Wiring Harness Replacement</i>	10
<i>Emergency Stop Switch Replacement</i>	10
<i>Emergency Stop Button Replacement</i>	10
<i>Touch Pad Membrane Replacement</i>	11
<i>Battery Charger Replacement</i>	12
<i>Limit Switch Replacement</i>	12
<i>Limit Switch Rod Replacement</i>	13
<i>Strap Replacement</i>	14
<i>Drum Replacement</i>	15
<i>Strap Roll Replacement</i>	16
<i>Motor and Transmission Replacement</i>	17
<i>CBLM Plate Replacement</i>	18
Programming	20
Service Mode	20
<i>How do I enter into service mode? :</i>	20
<i>How do I adjust the current limiter mode? :</i>	20
<i>How to read the number of cycles made by the Maxi Sky 440:</i>	21
<i>How to reset service light:</i>	21
<i>How to return to normal mode:</i>	21
<i>Conversion table</i>	22
Care and Maintenance	23
<i>Preventive Maintenance Schedule</i>	23

Table of Contents

<i>User Inspections</i>	23
<i>Inspections by an Authorized Service Technician</i>	24
<i>Daily Checklist</i>	25
<i>Inspection and Cleaning</i>	25
<i>Handling and Storage</i>	26
<i>Verification of the Charger's Power Source</i>	27
<i>Sling Inspection and Care</i>	27
<i>Annual Inspection</i>	27
<i>Maintenance Requirements</i>	27
Troubleshooting	28
Labels on the Lift	29
Wiring Diagram	30
Technical Specifications	31
Dimensions	33

Safety Instructions

Warnings

- A. ARJO strongly advises that only ARJO designated parts, which are designed for the purpose, should be used on equipment and other ARJO supplied appliance to avoid injuries attributable to the use of inadequate parts. ARJO's conditions of sale make specific provisions confirming no liability in such circumstances. Our policy is one of continuous development, and we, therefore reserve the right to change specifications without notice.
- B. Unauthorized modifications on any ARJO equipment may affect its safety and are in breach of any warranty on it. ARJO will not be held responsible for any accidents, incidents or lack of performance that occur as a result of unauthorized modifications to its products.
- C. Dangerous substances: If using hazardous substances be sure how to handle them and refer to applicable information. When in doubt, refer to the local authorities for health and safety requirements.
- D. It is strongly recommended that every technician follows the procedures as indicated in this manual. Every procedure has been studied in perspective on minimizing the risks either for the technician or the ceiling lift. Even if some of the procedures are not the shortest ones, they are the most effective on a long term basis.

Equipment Identification

The unit's identification number (specification, model, serial number) appears on a silver name plate underneath the housing of the lift.

- Replace any precautionary or instruction labels that cannot be easily read.

Shock Prevention

- DO NOT touch or use a lift with bare conductors or a damaged power cord. Electrically live equipment can electrocute a patient. If the lift or charger has any exposed or damaged wires, contact your local dealer immediately.
- Do not splash or expose electric parts of the device to water or moisture.
- Check nameplate for voltage and frequency requirements. These requirements differ by country. Do not attempt to use the lift in an area that has a different voltage and cycle requirement.

Fire and Explosion Prevention

WARNING: Dispose of the batteries safely. Batteries may explode, leak and cause personal injuries if disposed improperly. If battery acid comes into contact with skin or eyes, flush immediately with water.

- Do not dispose of batteries in fire.
- Do not short the battery terminals.
- For recycling and disposal of the batteries, the rules according to the WEEE directive (Waste of Electronic and Electrical Components) as well as local laws and regulations must be followed. When returning batteries, insulate their terminals with adhesive tape. Otherwise, the residual electricity in used batteries may cause fire or explosion. The figure below shows the symbols for disposal and recycling.

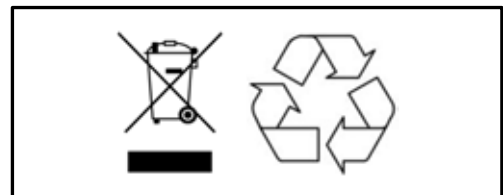

Safe Working Load

The **Maxi Sky 440** has been designed with a lifting capacity of 200 kg (440 lb).

Updating Instructions

VERIFY THAT THE LATEST UPDATES HAVE BEEN IMPLEMENTED

Verify on if there were any field correction bulletins, safety notices or technical bulletins that have been published since the last service.

This verification must be done to keep the product up to date according to safety and product improvements. Bulletins and notices can be generated as a result of an engineering change note, a safety incident report or a change to form/fit etc.

Example of a (TAN) Technical Advisory Notice



Technical Advisory Notice – TAN C

Issue date: 10-Dec-2018
Document ID: TAN-C-MAG-051-2018 Revision: 1

Title:	Introduction of Sara Steady Compact
Products affected:	Sara Steady Compact (Active Floor Lift)
Countries or Regions affected:	<input type="checkbox"/> All markets or <input type="checkbox"/> Continental Europe <input type="checkbox"/> North America <input type="checkbox"/> UKA <input type="checkbox"/> Aus./New Zealand <input type="checkbox"/> Central & Eastern Europe <input type="checkbox"/> Latin America or <input type="checkbox"/> Specific countries: _____
Function targeted:	<input checked="" type="checkbox"/> Sales <input type="checkbox"/> Service <input type="checkbox"/> Rental <input type="checkbox"/> Other _____
Reason for TAN:	<input type="checkbox"/> Instruction of repair/replacement <input type="checkbox"/> Part related <input type="checkbox"/> Order related <input type="checkbox"/> Field Safety Action <input type="checkbox"/> Field Action (non-Safety) <input type="checkbox"/> Product modification <input type="checkbox"/> Activity upon customer request <input checked="" type="checkbox"/> Other: <u>Market Expansion</u>

Note: The TAN becomes effective once it is distributed after approval. See last page for approval dates.

1. Background

This notice is to announce the introduction of Sara Steady Compact in new markets.

2. Scope

Sara Steady Compact is a mobile standing and raising aid, with a Safe Working Load of 182 kg (400 lb), intended to assist caregivers in hospitals, nursing homes, assisted living, group homes and home care facilities to lift and transfer patients/residents from one place to another e.g. to and/or from a chair, wheelchair, bedside, bath, shower/toilet chair or toilet. Sara Steady Compact has a similar design to Sara Steady. It is however designed for smaller patients.

This implementation phase releases the Sara Steady Compact for the following markets:

Print out and copies of this document have to be checked for validity and correctness before use. Page 1 of 3

Product Description

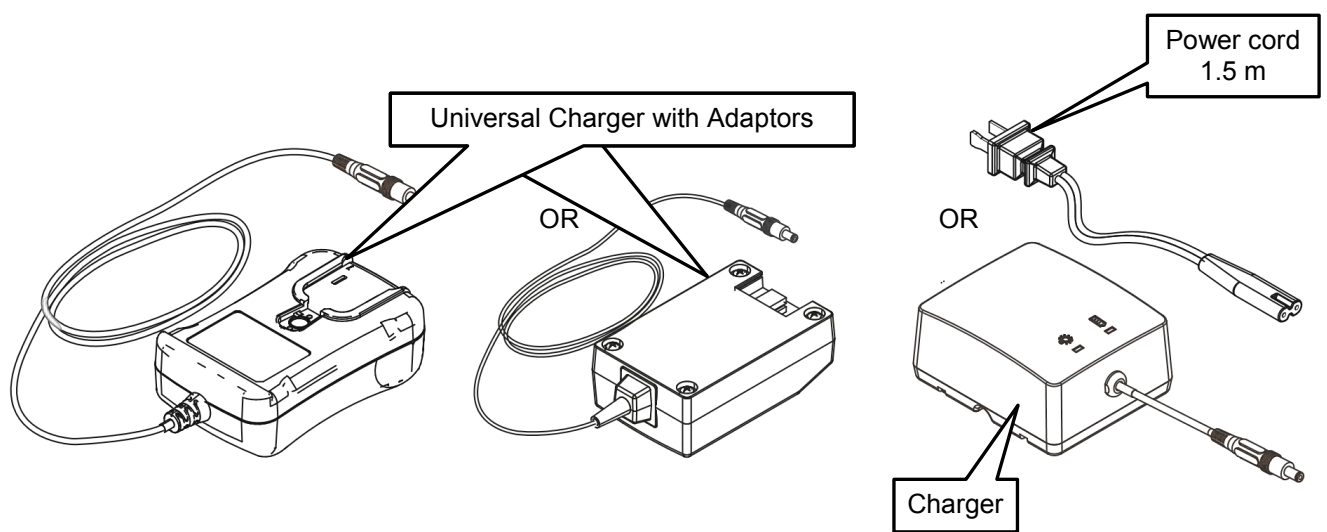
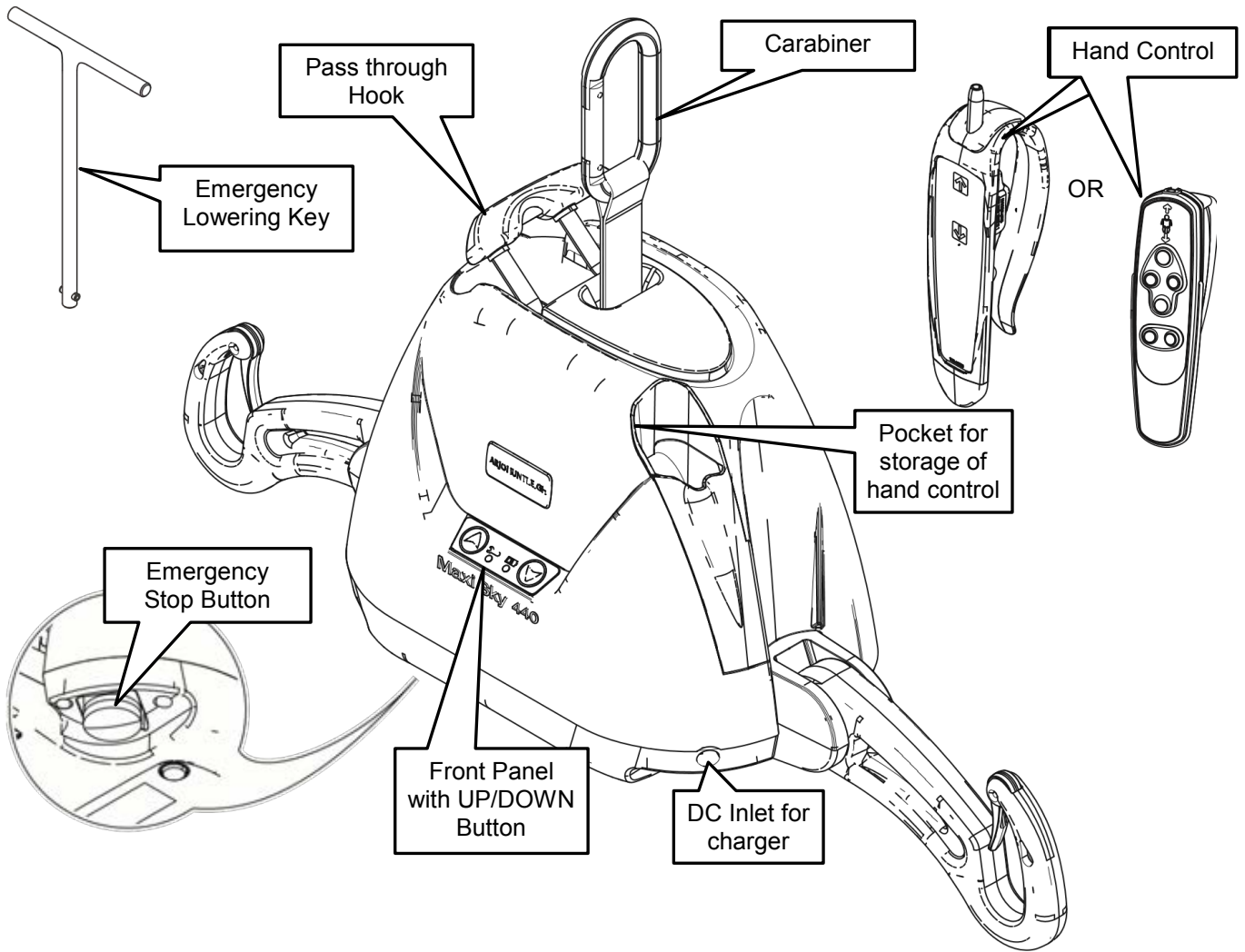

Service Procedures

Hand Control Replacement

Required tools:

- Screwdriver Torx 20
1. Unplug the hand control from under the lift.
 2. If a cable clamp is securing the hand control cable to the bottom cover, unscrew one of the two screws and only loosen the other one. This will help to reinstall the new handset. Remove the hand control.
 3. Install the new hand control cable under the cable clamp making sure it is threaded from the outside to the inside as shown.
 4. Leave approximately 50 mm (2 in) of cable passed the cable clamp and tighten the two cable clamp screws.
 5. Connect the new cable making sure that it latches in place. Pull gently to confirm that the connector is secure.

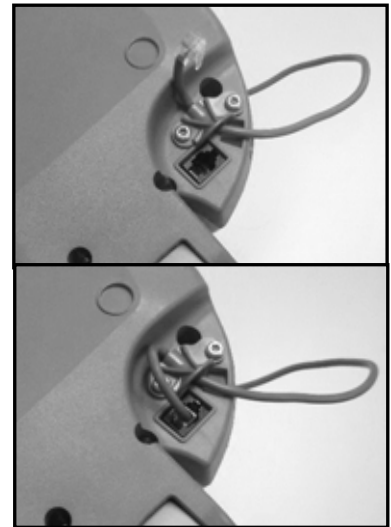

Bottom Plastic Cover Replacement

Required tools:

- Screwdriver Torx 20
 - Small flat head screw driver
1. Remove the carabiner from the strap.
 2. Follow the *Hand Control Replacement* instructions above to remove the hand control
 3. Put the lift on a flat surface. Place it on a cloth in order to avoid scratching the cover.
 4. Turn the lift upside down to remove the bottom part. Unscrew the 8 screws with an 11 cm long (4-1/4") T20 Torx screwdriver.
 5. Lift the cover to access the push button.
 6. Turn the locking clip counter-clockwise to release the push button switch assembly and pull it apart.

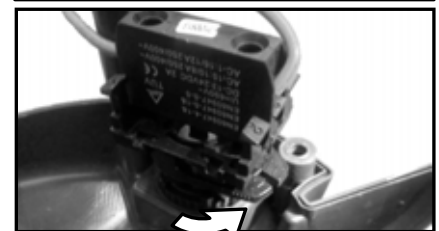
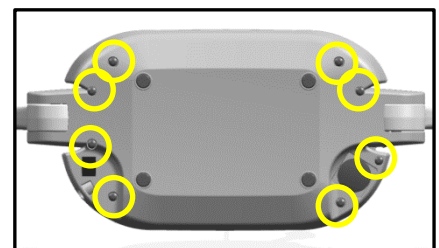

Note: Older models may be equipped with a metal locking spring. In this case, insert a small head screwdriver in the groove to release the locking spring.

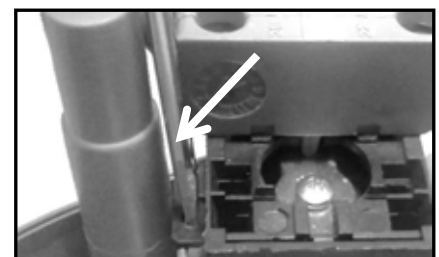

Service Procedures

7. Unscrew the ring surrounding the push button switch and remove it.
8. Replace the defective bottom cover with a new one.
9. Put the push button switch assembly back by inserting it from under the cover then screwing it in place.
10. Reinstall the switch to the button housing and turn the locking clip clockwise to secure it in place.

Gently pull the switch up to make sure that the clip (or clip spring) is retaining the assembly.

11. Put the lift upside down to place the bottom cover back with the eight screws. Do not over tighten.
12. Remove the unit's identification label from the old cover and affix it to the new one. Replace it if necessary.

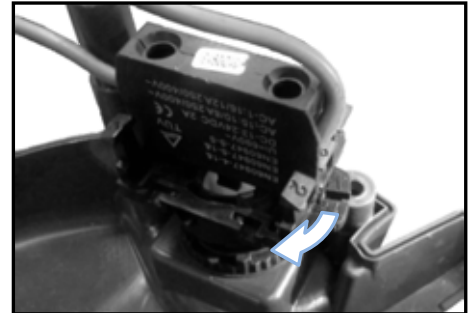
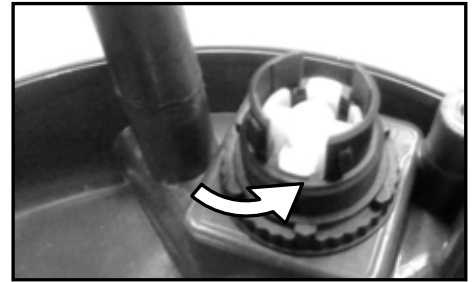

Main Plastic Cover Replacement

Required tools:

- Small flat-head screwdriver
- Screwdriver Torx 20



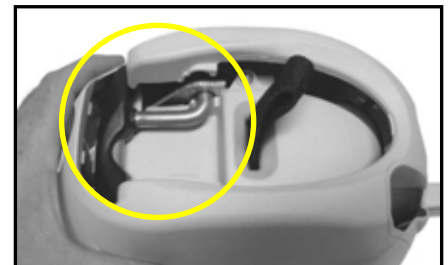

Refer to “Bottom Plastic Cover Replacement” on page 4 to remove the bottom part.

1. Turn the lift and unfold the foldable support.
2. Unclip the main cover from the top by squeezing each end with both hands.
3. Completely fold the Pass Through Hook and guide it through the opening while lifting the top cover.
4. Remove the main cover and unplug the touch pad membrane.
5. Remove the hand control connector PCBA (see “Hand Control and Charger Interface Circuit” on page 9 for details)

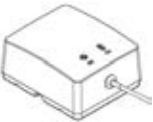

Service Procedures

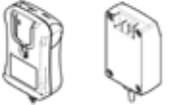
- Install the proper touch pad membrane onto the plastic cover according to the charger that accompanies the lift.

Battery Charger	Touch pad membrane to install
	
	

- Install the new plastic cover.
- Connect the touch pad membrane to the main circuit board. Refer to “Touch Pad Membrane Replacement” on page 11 for specific note concerning membrane connection.
- Reinstall the hand control connector PCBA.
- Move the cover down until it snaps to the strap inlet.
- Turn the lift upside down.
- Reinstall the bottom plastic cover with the 8 screws. Do not over tighten (refer to “Bottom Plastic Cover Replacement” on page 4).

Batteries Replacement

Required tools:

- Screwdriver Torx 20
- Small flat head screwdriver

- Remove the covers (see “Main Plastic Cover Replacement” on page 5 for details). Note that it is not necessary to remove the switch from the bottom cover.
- Loosen the 2 screws from the battery support retaining the batteries with a Torx 20 screwdriver.

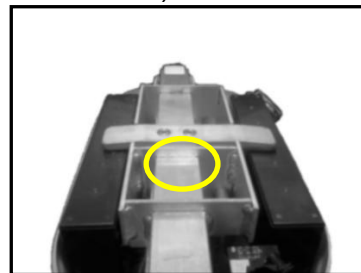

- Remove batteries and unplug terminals.
- Replace both batteries.
- Reconnect the wires to battery terminals making sure to respect the polarity. Batteries must be position so that terminals are placed near the plastic cover rather than beside the metal frame.



- Make sure to route the wires correctly.
- Reinstall the battery support.
- Reinstall the top plastic cover.
- Clip the push button contact assembly and reinstall the bottom plastic cover (refer to “Bottom Plastic Cover Replacement” on page 4).

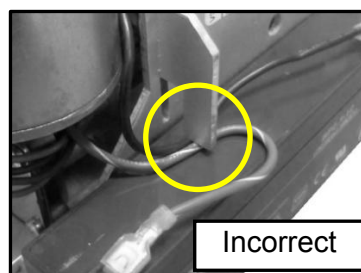
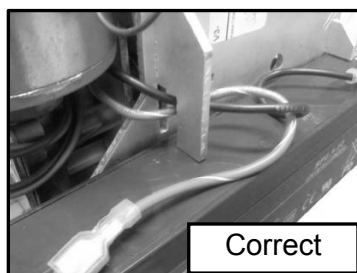

Fuse Replacement

Required tools:

- None
1. Refer to "Batteries Replacement" above to access the fuse holder.
 2. Pull out the fuse holder and open it (unscrew both parts) to access the fuse.
 3. Remove the fuse and replace it with a new one (PN C8FGMA10).
 4. Reinstall the fuse holder.
 5. Reposition the fuse wiring as close as possible to the PCBA to prevent it from interfering with the cover when putting it back.
 6. Refer to "Main Plastic Cover Replacement" on page 5 to reinstall both plastic covers.



Pass Through Hook Replacement

Required tools:

- Retaining ring pliers
1. Refer to "Main Plastic Cover Replacement" on page 5 to remove the plastic covers.
 2. Locate the Pass Through Hook and remove the retaining rings, placed on each sides of the handle, with appropriate pliers.
 3. Remove both plastic bushings and remove the handle.
 4. Install the new handle by first inserting the longest shaft into the hole.
 5. Reinstall both bushings.
 6. Insert the retaining rings on each side of the handle. Make sure that the rings are in place and safely retaining the handle.
 7. Refer to "Main Plastic Cover Replacement" on page 5 to reinstall the plastic covers.

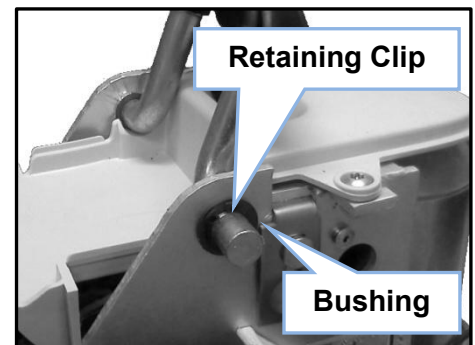

Strap Inlet Replacement

Required tools:

- Screwdriver Torx T20
 - Retaining ring pliers
1. Refer to "Main Plastic Cover Replacement" on page 5 to reinstall the plastic covers.
 2. Refer to "Pass Through Hook Replacement" above to remove the handle (Pass Through Hook).
 3. Remove both screws on the strap inlet with a Torx T20 screwdriver.
 4. Replace the new strap inlet and fix it in place with the screws on each side.
 5. Refer to "Pass Through Hook Replacement" above to reinstall the handle.
 6. Refer to "Main Plastic Cover Replacement" on page 5 to reinstall both plastic covers.

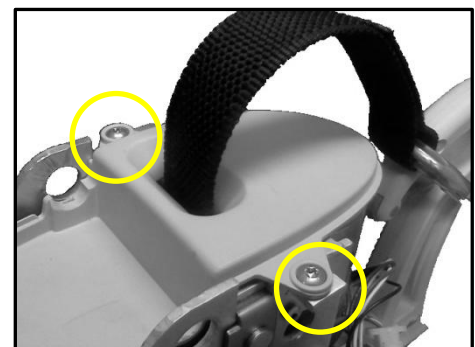

Service Procedures

Folding Arm Replacement

Required tools:

- Small flat head screwdriver
- Long nose pliers
- Plastic hammer
- Punch

1. Refer to "Main Plastic Cover Replacement" on page 5 to remove the plastic covers.

2. Locate the folding supports and remove both retaining clips using a small flat head screwdriver.

3. Push out both clevis pins from the folding arm using the punch and the plastic hammer.

4. Replace the arm. Make sure to align holes. Reinsert both clevis pins with a plastic hammer. No grease is required on clevis pins. Mate both clevis pin's flat sides to prevent them from turning.

5. Reinstall both retaining clips.

6. Verify arm operation by rotating it back and forth.

7. Make sure that the safety latches are in place and that they revert to closed position when they are released.

8. Refer to "Main Plastic Cover Replacement" on page 5 to reinstall both covers.

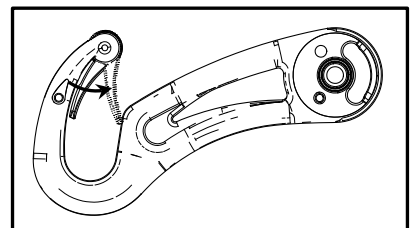
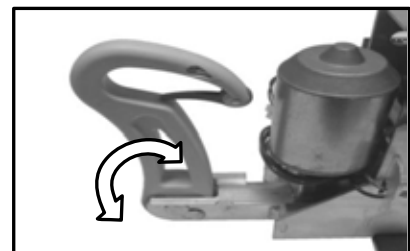
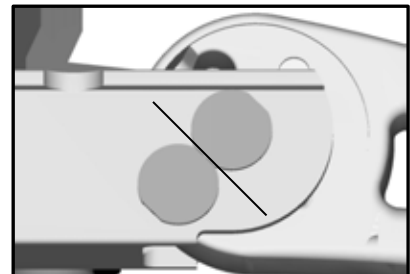
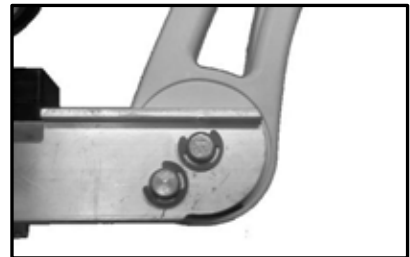

Hand Control and Charger Interface Circuit

Required tools:

- Screwdriver Torx T20
1. Refer to “Bottom Plastic Cover Replacement” on page 4 to remove the bottom cover and access the interface circuit.
 2. Remove the hand control and charger interface circuit board using a Torx T-20 screwdriver.
 3. Unplug the connector and replace the circuit board with a new one.
 4. Plug the connector to the new circuit board and screw the circuit board to the cover.
 5. Refer to “Bottom Plastic Cover Replacement” on page 4 to reinstall the bottom cover.

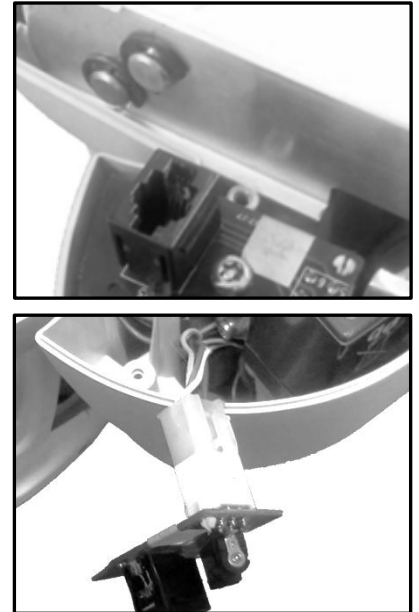

Main Circuit Board Replacement

Required tools:

- 8 mm socket tool
- Small flat head screwdriver
- Screwdriver Torx T20

Note: Adequate ESD equipment must be used, when manipulating the circuit board, to prevent any damages to occur due to anti-static discharge.

1. Refer to "Main Plastic Cover Replacement" on page 5 to remove the plastic covers.
2. Disconnect the batteries.
3. Unscrew the two locknuts with an 8 mm socket tool.

4. Unplug the main connector from the circuit board.
5. Unplug the motor.
6. Replace the main circuit board.
7. Fix the new main circuit board on the frame with the two locknuts. Do not over tighten.
8. Plug in the main connector. Plug in the motor. Reconnect the batteries.
9. Reinstall the main cover as indicated in the "Main Plastic Cover Replacement" on page 5.
10. Refer to “Batteries Replacement” on page 6 to reinstall the batteries, support and bottom cover.

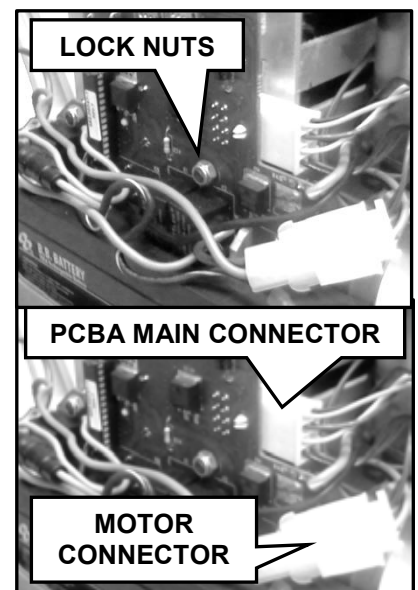

Service Procedures

Wiring Harness Replacement

Required tools:

- 8 mm socket
1. Refer to “Main Circuit Board Replacement” on page 9 to remove the main circuit board.
 2. Unplug wiring from the limit switch.
 3. Replace wiring harness with a new one.
 4. Connect both wires to the limit switch making sure not to use the centre terminal of the switch.
 5. Plug the other end into the main circuit board.
 6. Reinstall the main cover as indicated in the “Main Plastic Cover Replacement” on page 5.



Emergency Stop Switch Replacement

Required tools:

- Screwdriver Phillips #2
1. Refer to “Bottom Plastic Cover Replacement” on page 4 to access the Emergency Stop Switch and to disassemble it from the cover.
 2. Unscrew the 2 Phillips screws with a Phillips #2 screwdriver to remove the wires.
 3. Insert the wires into the new switch and secure them by tightening the Phillips screws.
 4. Refer to “Bottom Plastic Cover Replacement” on page 4 to reinstall the switch assembly and the covers.

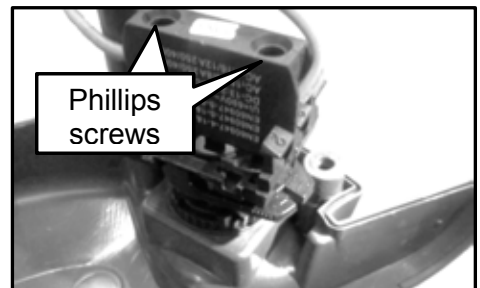

Emergency Stop Button Replacement

Required tools:

- None

Refer to “Bottom Plastic Cover Replacement” on page 4. This procedure includes all the steps required to remove the covers, disassemble the switch from the button and disassemble the button from the cover as well as steps to put these elements back together.

Touch Pad Membrane Replacement

Required tools:

- None
1. Refer to "Main Plastic Cover Replacement" on page 5 to access the touch pad membrane.
 2. Remove the membrane located in front of the main cover.
 3. Carefully insert the flat cable connector of the membrane into the hole then apply the membrane sticker to the cover.
 4. Connect the membrane connector to the main circuit board. See note below pertaining to the touch pad membrane being installed.



Note pertaining to the 4-pin connector membrane (001.08070.33):

Be very careful to place the back of the connector facing the PCBA, see Figure 1. Main circuit board revision 13 and up is featuring a 5-pin connector for connecting the membrane, care should be taken when connecting the membrane to a PCBA featuring a 4-pin connector leaving the 5th pin unconnected.

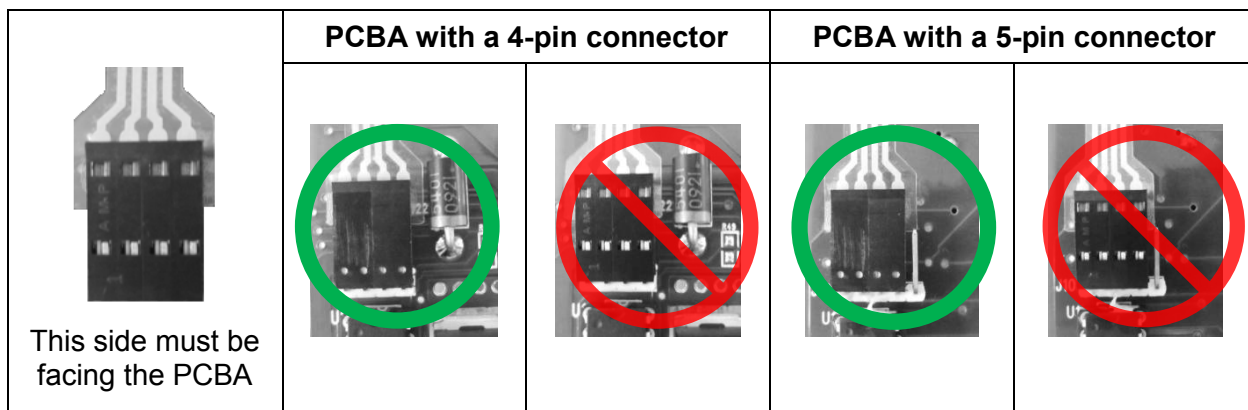

FIGURE 1

Note pertaining to the 5-pin connector membrane with charge indicator (001-08100-33):

Be very careful to place the back of the connector facing the PCBA, see Figure 2. This membrane has been designed to be used with battery charger 700-24201 and 700-15567-B, it is compatible only with main circuit board of revision 13 and higher. **Do not connect it to a PCBA featuring a 4-pin connector.**

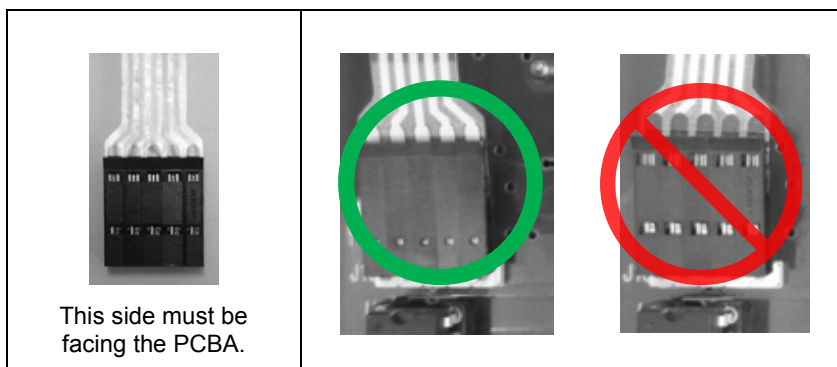

FIGURE 2

5. Refer to "Main Plastic Cover Replacement" on page 5 to reinstall the plastic covers.

Service Procedures

Battery Charger Replacement

Required tools:

- None

Battery Charger 700.13510.33 (OBSOLETE)

This charger has been replaced by the wall mounted charger 700-15567-B which requires to have the touch pad membrane 001-08100-33 (featuring a charge indicator light) on the unit. For this indicator to function properly, the main circuit board shall be replaced with one of revision 13 or higher if not already present.

Battery Charger 700-24201 (OBSOLETE)

This charger has been replaced by the wall mounted charger 700-15567-B which requires to have the touch pad membrane 001-08100-33 (featuring a charge indicator light) on the unit.

Caution: Do not use charger 700-15567-B or 700-24201 with a PCBA of revision below 13.

1. Before replacing the charger, remove the Main Plastic cover and check if the PCBA is featuring a 5-pin connector (revision 13 or greater). If not, the PCBA has to be replaced as well, refer to "Main Circuit Board Replacement" on page 9 to replace the circuit board.
2. Refer to "Touch Pad Membrane Replacement" on page 11 to replace the touch pad membrane.

Limit Switch Replacement

Required tools:

- 3/16" Socket

1. Refer to "Main Plastic Cover Replacement" on page 5 to remove plastic covers.
2. Unplug the two wires from the limit switch.
3. Unscrew the two locknuts from the other side of the frame with a 3/16" socket.

4. Install the new limit switch on the frame and screw in the locknuts. Do not over tighten the locknuts. Make sure to reposition the contact blades under the upper limit shaft as shown.

Plug the two wires back into both ends of the limit switch. Never use the centre pin (see "Wiring Diagram" on page 30).

5. Refer to "Main Plastic Cover Replacement" on page 5 to reinstall the plastic covers.

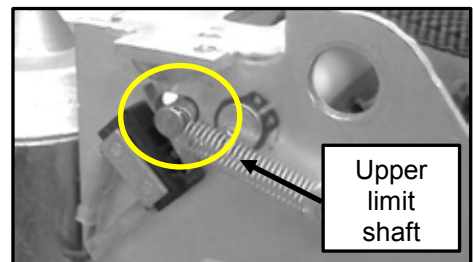
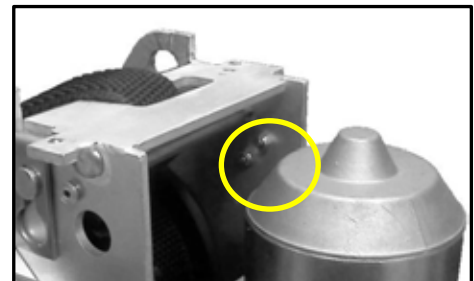

Limit Switch Rod Replacement

Required tools:

- Cutter pliers
- Long nose pliers
- Pop-rivet installation tool

1. Refer to "Main Plastic Cover Replacement" on page 5 to remove plastic covers.
2. Remove the spring from the upper limit shaft.

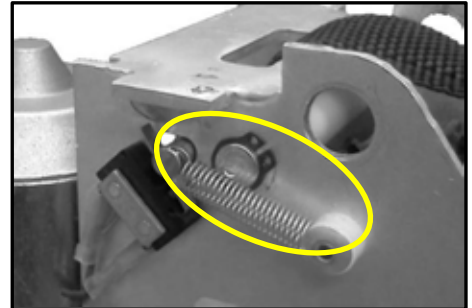

3. Pry out the rivet with cutter pliers and remove the upper limit shaft.

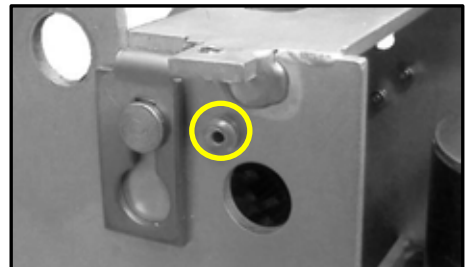

4. Insert the new upper shaft. Fix the rivet (PN 000.00887) to maintain the upper shaft using a pop rivet installation tool.
5. Put the spring back on the upper shaft.
6. Refer to "Main Plastic Cover Replacement" on page 5 to reinstall the plastic covers.

Service Procedures

Strap Replacement

Required tools:

- 4 mm- Allen Key

1. Refer to "Main Plastic Cover Replacement" on page 5 to remove plastic covers.
2. Refer to "Strap Inlet Replacement" on page 7 to remove the strap inlet.
3. Refer to "Main Circuit Board Replacement" on page 9 to remove the main circuit board.
4. Push on the CBLM block plate to disengage the transmission.

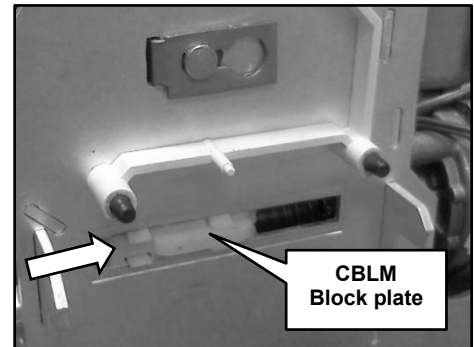

5. Maintain the CBLM block plate and pull the strap out completely from the drum.
6. With a 4 mm Allen key, remove the two button screws which maintains the strap to the drum.

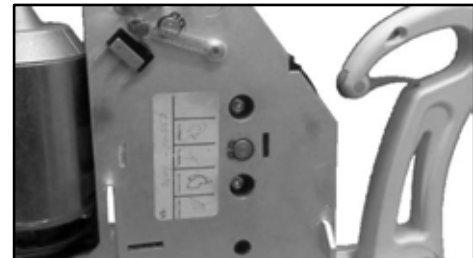

7. Insert the new strap through the strap inlet opening making sure to first insert the end where the identification tag is affixed.

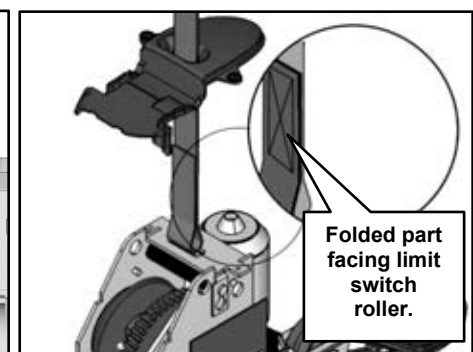
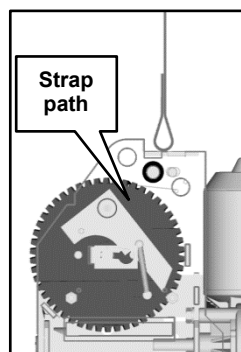

8. Maintain the CBLM block plate when turning the drum down until the strap is completely wound up around the drum, then release the CBLM block plate.
9. Reinstall the circuit board as per "Main Circuit Board Replacement" on page 9.
10. Refer to "Strap Inlet Replacement" on page 7 to reinstall the strap inlet.
11. Refer to "Pass Through Hook Replacement" on page 7 to reinstall the pass through hook.

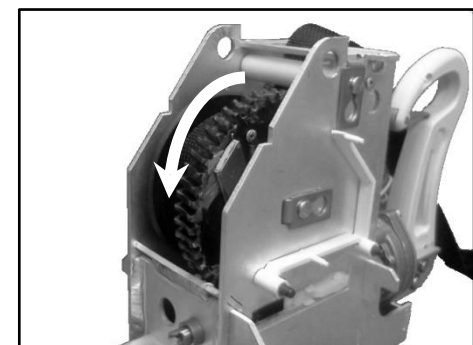

12. Refer to "Main Plastic Cover Replacement" on page 5 to reinstall the plastic main cover.
13. Refer to "Bottom Plastic Cover Replacement" on page 4 to reinstall the plastic bottom cover.

Drum Replacement

Required tools:

- Retaining ring pliers

1. Refer to "Main Plastic Cover Replacement" on page 5 to remove plastic covers.
2. Refer to "Pass Through Hook Replacement" on page 7 to remove the Pass Through Hook
3. Refer to "Strap Inlet Replacement" on page 7 to remove the strap inlet.
4. Refer to "Main Circuit Board Replacement" on page 9 to remove the main circuit board.
5. Remove the snap ring that maintains the drum shaft with retaining ring pliers. Remove the shaft.

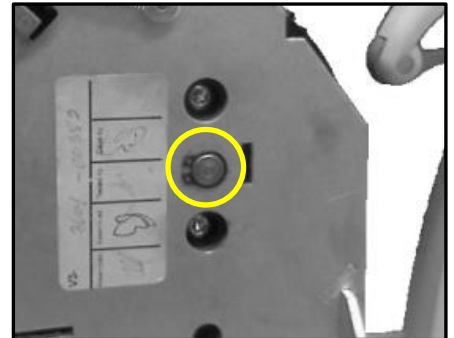

6. Remove the snap ring that maintains the strap roll shaft with retaining ring pliers. Remove the shaft and the strap roll.

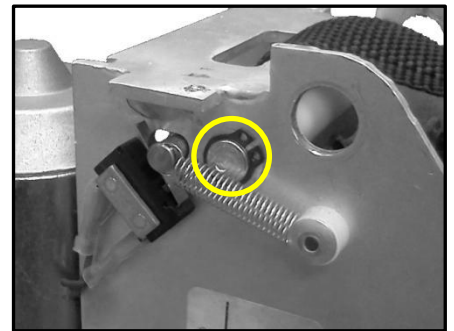

7. Remove the drum.
8. Route the strap through the opening on top of the frame. Insert the new drum into the frame then insert the shaft to maintain it. Apply food type grease (PN P8100) over the gear (2 - 3 gr).
9. Insert the snap ring to secure the shaft.
10. Reinsert the strap roll then insert the shaft through it. Make sure that the strap is behind the strap roll. Put the snap ring back to secure the shaft.

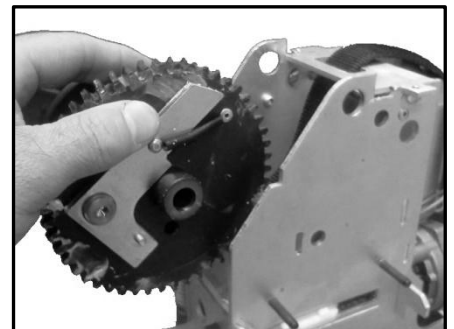

11. Reinstall the circuit board as per "Main Circuit Board Replacement" on page 9.
12. Refer to "Strap Inlet Replacement" on page 7 to reinstall the strap inlet.
13. Refer to "Pass Through Hook Replacement" on page 7 to reinstall the pass through hook.
14. Refer to "Main Plastic Cover Replacement" on page 5 to reinstall the plastic covers.

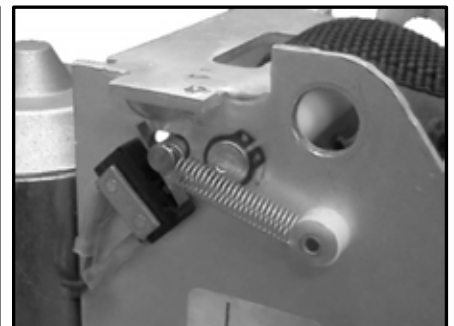
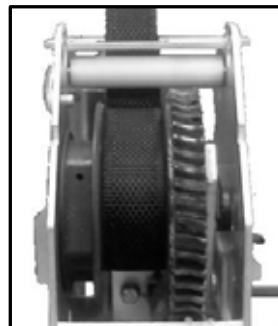

Service Procedures

Strap Roll Replacement

Required tools:

- Retaining ring plier
1. Refer to "Main Plastic Cover Replacement" on page 5 to remove plastic covers.
 2. Refer to "Pass Through Hook Replacement" on page 7 to remove the Pass Through Hook.
 3. Refer to "Strap Inlet Replacement" on page 7 to remove the Strap Inlet.
 4. Remove the snap ring that holds the strap roll shaft using appropriate pliers and remove the shaft.
 5. Remove the strap roll and replace it with a new one.
 6. Reinsert the strap roll, apply grease (PN 001.14140) over the strap roll shaft and reinsert it into the strap roll. Make sure that the strap is placed behind the strap roll. Put the snap rings back.
 7. Refer to "Strap Inlet Replacement" on page 7 to reinstall the Strap Inlet.
 8. Refer to "Pass Through Hook Replacement" on page 7 to reinstall the Pass Through Hook.
 9. Refer to "Main Plastic Cover Replacement" on page 5 to reinstall the plastic covers.

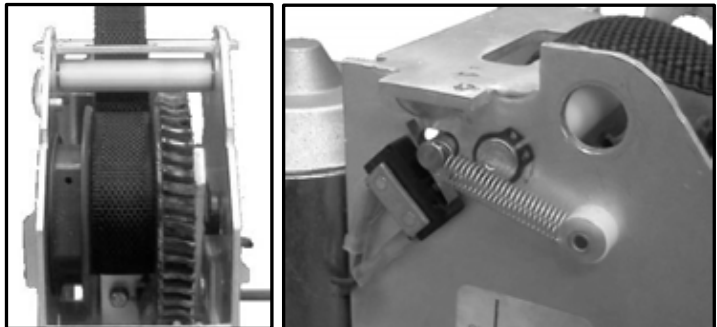

Motor and Transmission Replacement

Required tools:

- 12 mm socket hex tool
- Ratchet

1. Refer to "Main Plastic Cover Replacement" on page 5 to remove plastic covers.
2. Refer to "Main Circuit Board Replacement" on page 9 to access and remove the circuit board.
3. Refer to "Strap Inlet Replacement" on page 7 to remove the Pass Through Hook and the Strap Inlet.
4. Refer to "Batteries Replacement" on page 6 to remove the batteries.
5. Refer to "Drum Replacement" on page 15 to remove the drum from the frame.

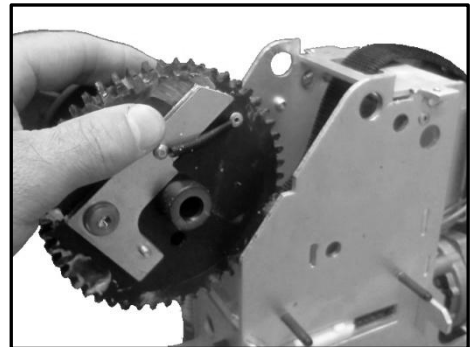

6. Remove the three screws that maintains the motor with a 12 mm socket.
7. Remove the motor with the shaft assembly from the frame.

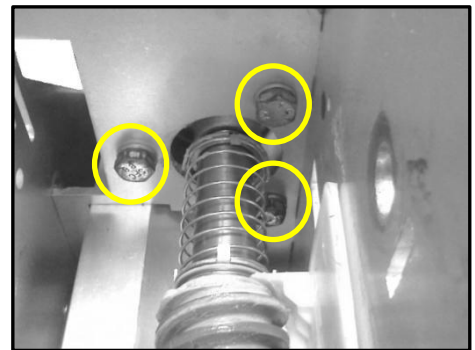

8. Remove the setscrew from the shaft assembly and pull the shaft out from the motor.
9. Replace the defective part with a new one and reassemble the shaft to the motor.
10. Apply Loctite 243 over the setscrew threads and tighten it to a torque of 4 N·m (± 1 N·m) without compressing the drive shaft assembly spring.
11. Apply food type grease (PN P8100) over the worm gear.

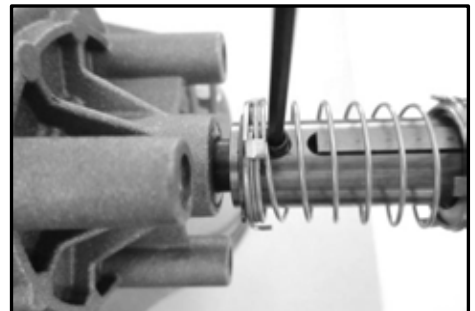

12. Insert the motor shaft into the frame making sure that the bearing is placed over the shaft such as the writing on the bearing is facing outward.

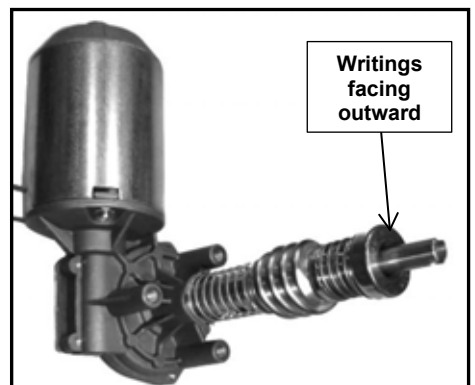

Service Procedures

13. Couple the CBLM block plate into the slot at the end of the worm.

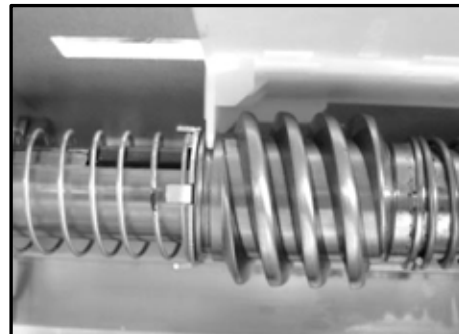

14. Reinstall the three screws that maintains the motor.
15. Test the CBLM plate attached with the worm. Move the plate left and right, the plate must easily move with the worm.

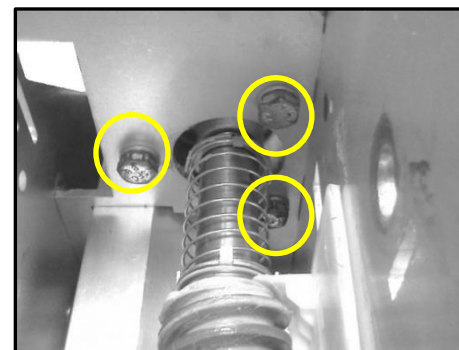

16. Refer to "Drum Replacement" on page 15 to reinstall the drum.
17. Refer to "Strap Roll Replacement" on page 16 to reinstall the drum strap roller.
18. Reinstall the circuit board (see "Main Circuit Board Replacement" on page 9 for details).
19. Reinstall the batteries (see "Batteries Replacement" on page 6 for details).
20. Reinstall the strap inlet (see "Strap Inlet Replacement" on page 7 for detail).
21. Reinstall the Pass Through Hook (see "Pass Through Hook Replacement" on page 7 for details).
22. Reinstall the plastic covers (see "Bottom Plastic Cover Replacement" on page 4 and "Main Plastic Cover Replacement" on page 5 for details).

CBLM Plate Replacement

Required tools:

- Long nose plier
1. Refer to "Motor and Transmission Replacement" on page 17 to access the CBLM block plate.
 2. Unclip the CBLM block plate with a long nose plier by pulling it from the inside.
 3. Clip the new CBLM block plate from the inside of the frame by pushing it with a flat head screwdriver.
 4. Slide the CBLM block plate a few times to remove any residue from the slot. It must move easily with very low friction.
 5. Refer to "Drum Replacement" on page 15 to reinstall the motor, the shaft assembly and the drum.
 6. Reinstall the circuit board (see "Main Circuit Board Replacement" on page 9 for details).
 7. Reinstall the batteries (see "Batteries Replacement" on page 6 for details).

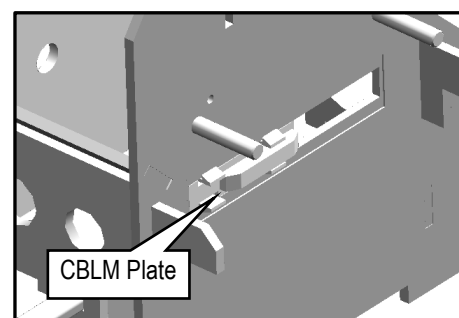
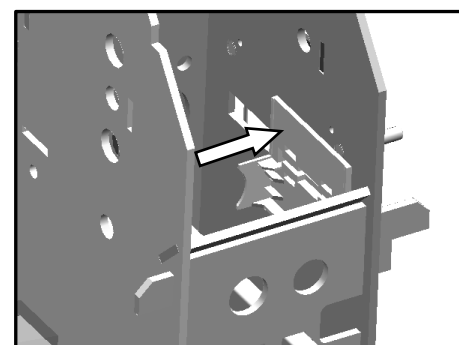

Service Procedures

8. Reinstall the strap inlet (see “Strap Inlet Replacement” on page 14 for detail).
9. Reinstall the Pass Through Hook (see “Pass Through Hook Replacement” on page 7 for details).
10. Reinstall the plastic covers (see “Bottom Plastic Cover Replacement” on page 4 and “Main Plastic Cover Replacement” on page 5 for details).

Programming

Service Mode

The Maxi Sky 440 service hand control (# 700.13620.33 or 700-13840 – not included) is required to access the service mode (service light setting).

Note: In order to prevent the user from accidentally entering into service mode while using the lift, the three buttons hand control is not included. The Maxi Sky 440 must be programmed by an authorized technician only.

How do I enter into service mode? :

1. Unplug the hand control from the Maxi Sky 440.
2. Open the Maxi Sky 440 bottom and main cover.
3. Plug the service hand control into the Maxi Sky 440.
4. Unplug the red/white wire from the battery and push the UP button a few seconds to drain the remaining energy out of the circuit board.
5. Push and hold the DOWN and X buttons at the same time.
6. Plug the red and white wire to the battery. Wait a few seconds.
7. You will hear 5 beeps from the Maxi Sky 440. Now you can release the hand control buttons. A red light confirms that you are in service mode.
8. Press the UP button to select the parameter you want to adjust (refer to table below).

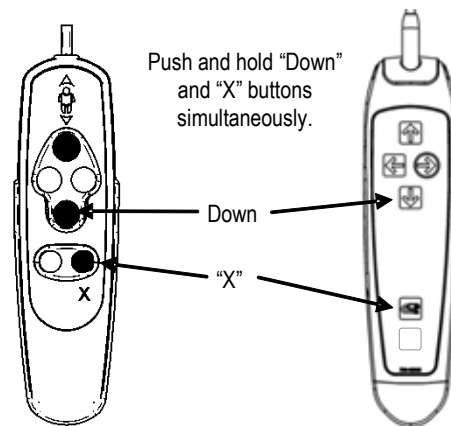

Beeps	Parameter
1	Current limiter
2	-
3	-
4	Number of cycle
5	Reset service light
6	-

How do I adjust the current limiter mode? :

1. Select parameter 1 in the service mode (1 beep).
2. After the beep, press the X button on the hand control to select the option. You are going to hear one beep which indicates your choice. You are now in the current limiter mode.
3. Press the UP button to increase the lift capacity or the DOWN button to decrease it. Each time you press the UP button, you add approximately 5 lb to the lifting capacity. Each time you press the DOWN button you reduce the lifting capacity by approximately 5 lb from the lifting capacity. Each adjustment of the capacity corresponds to 1 beep. A 3-beep acknowledgement means that the adjustment limit has been reached.
4. Press on the X button on the hand control to confirm the new lift capacity.

How to read the number of cycles made by the Maxi Sky 440:

1. Select parameter 4 in the service mode (4 beeps).
2. After you have heard the 4 beeps, push on the X button on the hand control to select the option. You will hear a certain number of beeps. The number of beeps indicates the number of cycles performed by the Maxi Sky 440 (each individual beep represents approximately 250 additional cycles), see “Conversion table” on page 22.

How to reset service light:

1. Select parameter 5 in the service mode (5 beeps).
2. After you have heard the 5 beeps, push the X button on the hand control to select the option (reset the service light).
3. To reset the service light, push the UP button on the hand control until you hear 3 beeps. Each time you push the UP button, you increase the number of beeps that you will hear.
4. After 3 beeps, push the X button on the hand control to select the option (reset the service light), you will hear 1 beep confirming your selection.
5. The service light is reset.

How to return to normal mode:

6. Unplug the red/white wire from the battery and push the UP button a few seconds to drain the remaining energy out of the circuit board.
7. Plug the red/white wire into the battery.
8. The Maxi Sky 440 is back into normal mode.

Programming

Conversion table

Number of beeps	Number of cycles
1	257
2	514
3	771
4	1029
5	1286
6	1543
7	1800
8	2057
9	2314
10	2571
11	2829
12	3086
13	3343
14	3600
15	3857
16	4114
17	4371
18	4629
19	4886
20	5143
21	5400
22	5657
23	5914
24	6171
25	6429
26	6686
27	6943
28	7200
29	7457
30	7714

Lift service light is turned on

Lift service light or/and warning beeps audible

Care and Maintenance

Preventive Maintenance Schedule

The equipment is subjected to wear and tear, and the following maintenance instructions must be acted upon when specified to ensure that the equipment remains within its original manufacturing specifications. Care and maintenance must be carried out in accordance with the preventive maintenance schedule below. Customer obligations must be carried out by qualified personnel in accordance with the instructions in this manual.



WARNING: The maintenance described in the following checklist is the minimum that the manufacturer recommends. In some cases more frequent inspections should be carried out. Continuing to use this equipment without conducting regular inspections or when a fault is found will seriously compromise the safety of the user and of the patient. Local regulations and standards may be higher than those of the manufacturer. A load test is recommended. Service and preventive maintenance can be arranged with the manufacturer. Preventive maintenance specified in this manual can prevent accidents and reduce repair costs.



WARNING: Safety related maintenance and authorized service must be carried out by qualified personnel, fully trained in servicing procedures by Arjo, and equipped with correct tools. Failure to meet these requirements could result in personal injuries and/or unsafe equipment.

User Inspections

Action/check	Initially	Before every use	Every 2 months	Every 4 months	Every year	Every 2 years
Lift device						
Inspect for missing hardware or broken enclosure.	X	X			X	
Inspect strap for wear.		X	X			
Inspect if pass through hook has any damage (seems loose or shows noticeable cracks).		X				
Recharge batteries.		X				
Inspect the folding sling supports for damages or cracks.					X	
Inspect wheels in track for damage, rust or cracks. Replace if damaged.					X	
Clean the track.				X		
Overall inspection by authorized personnel.					X	

Care and Maintenance

Action/check	Initially	Before every use	Every 2 months	Every 4 months	Every year	Every 2 years
Sling and hardware						
Check all sling attachments for sign of wear.		X				
Inspect sling material for wear or deterioration.		X				
Inspect sling straps for wear.		X				
Inspect for any defects or loose threads in the “stitched areas”.		X				
Clean sling as indicated on the tag.	When necessary					
Verify emergency stop button.				X		
Verify emergency lowering device.				X		

Inspections by an Authorized Service Technician

Action/check	Initially	Before every use	Every 2 months	Every 4 months	Every year	Every 2 years
Authorized Service						
Replace strap.						X
Inspect frame welds for cracks.					X	
Inspect transmission.					X	
Inspect connecting joints for proper attachment.					X	
Verify that the emergency brake on the drum is moving freely.					X	
Verify emergency devices for good functioning.					X	
Load test with SWL (maximum working capacity).					X	



WARNING: To avoid injuries that can be attributed to the use of inadequate parts, Arjo strongly advises and warns that only Arjo designated parts should be used on equipment and other appliances supplied by Arjo. Unauthorized modifications on any Arjo equipment may affect its safety. Arjo will not be held responsible for any accidents, incidents or lack of performance that occur as a result of any unauthorized modification to its products.

NOTE: If the product does not work as intended, immediately contact your local Arjo representative for support.



WARNING: Always reinstall the rail end stoppers (if removed) after servicing.

Care and Maintenance

Daily Checklist

The following procedures must be followed before each use:

- Charge the batteries. Connect the lift to the charger whenever the lift is not in use.
- Inspect the lift for any damage. If the lift casing does not look properly aligned, or there are any cracks or other damage on the lift, or there are parts missing, DO NOT USE IT. Contact your Arjo representative to have the lift serviced.
- Inspect the strap for any visible signs of wear, frays, loose threads or other damage (see Figure 3). If there is any evidence of damage, DO NOT USE IT. Contact your local Arjo representative to have the lift serviced.
- Inspect the sling for tears, frayed straps or loose stitching. If the sling has any of the above damage, DO NOT USE IT. Contact your local Arjo representative to have the sling replaced.
- Inspect the folding supports for any signs of cracking or damage. Inspect the carabiner at the top of the strap to ensure that it is properly attached.



WARNING: Before each use, make sure all rail end stoppers are in place and secured.

Inspection and Cleaning

To clean the Maxi Sky 440, wipe it down with a damp cloth using warm water and a disinfectant cleaner. Disinfectant wipes, supplied already impregnated with a 70% v/v solution of isopropyl alcohol, can also be used.

Rub the lift vigorously when using the wipes, to promote an effective disinfection of its entire surface. Do not use phenol, chlorine or any other type of solvent that may damage the finish.



WARNING: Do not splash, drench or immerse the unit in water.

To ensure a better rolling surface for the trolley wheels, clean the inside of the track every 4 months. To do so, insert a damp cloth in the opening and slide it from one end of the track to the other.

Care and Maintenance

Strap Inspection

If the strap is damaged and shows signs of wear, the acceptable load it can bear before rupture can drop rapidly and can endanger the patient or the caregiver.

Arjo recommends thoroughly inspecting the strap every two (2) months as follows:

1. Completely unwind the strap.
2. Look for any signs of wear such as loose threads in stitched areas, noticeable discoloration, or side and middle wear.

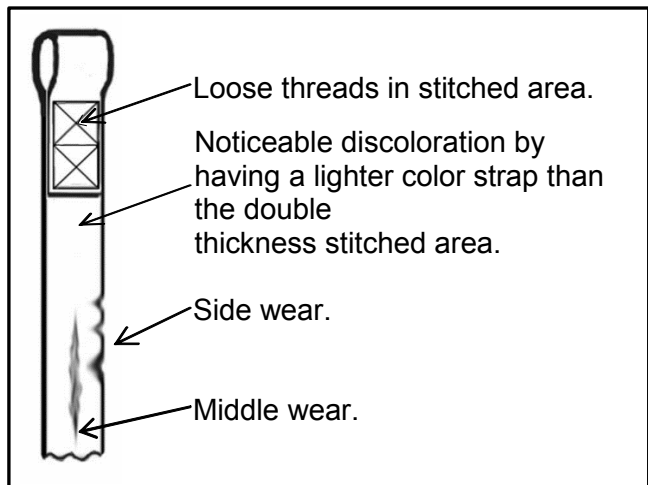

FIGURE 3



WARNING: If there are any signs of wear as indicated previously or other visual defects, the strap should be changed immediately. By continuing to use the lift without changing the strap, the caregiver and the patient's safety is greatly compromised.

NOTE: In any case, the manufacturer recommends changing the strap at least every two years. By continuing to use the lift without changing the strap, the caregiver and the patient's safety is greatly compromised.

Handling and Storage

Avoid violent impacts while transporting the lift. The lift should not remain stored for long periods of time without recharging the batteries.

NOTE: Even if the lift is not used, Arjo recommends charging the batteries at least every two weeks. This will prevent premature aging of batteries.

If you store or ship the Maxi Sky 440, ensure that the power is turned off (emergency button pushed in) beforehand.

Care and Maintenance

Battery Replacement

Arjo uses sealed lead-acid batteries in the ceiling lifts. These batteries do not have any memory effect. Therefore, batteries should not be completely discharged before recharging.

Replace the batteries when there is a noticeable reduction in the number of transfers that can be performed between charges. If you hear the Maxi Sky 440 beeping and notice a red light flashing, see the instructions in the “Troubleshooting” section of this manual to determine if there is a problem with the batteries.



To replace batteries, be sure to contact your local Arjo representative.

CAUTION: Do not attempt to use batteries that were not supplied by Arjo. These batteries are specially designed for Arjo charging systems. Attempting to use unauthorized batteries may seriously damage the lift and/or the charger.

Verification of the Charger’s Power Source

If the light does not illuminate when there are batteries correctly installed in the Maxi Sky 440, try the following:

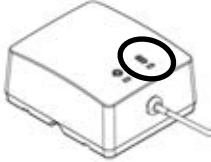
1. Make sure that the charger is correctly plugged into the AC outlet and verify the status of the charge indicator light according to charger model.

Charger model 700.13510.33		Charger model 700-24201 or 700-15567-B	
	Green light is on solid to indicate charging.		The yellow light on the lift flashes to indicate charging.

2. Make sure that the charger connector is properly connected to the unit.
3. Check the power of the AC outlet on the wall.
4. If the charger’s yellow or green light does not light up, contact your local Arjo representative for assistance.

Sling Inspection and Care

See the documentation that comes with your sling.

Annual Inspection

The Maxi Sky 440 and its accessories must be inspected annually by a qualified technician.



WARNING: The Maxi Sky 440 and accessories must be serviced every 12 months as a minimum requirement (see “Care and Maintenance”). Do not attempt to perform the inspection unless you are qualified to do so.

Maintenance Requirements

The Maxi Sky 440 is equipped with an electronic monitor that causes a red light to flash when a maintenance inspection is necessary. Arranging for scheduled inspections ensures the durability of the unit and the security of both patient and user.

Once that red light begins to flash, please contact your local Arjo representative in order to perform the necessary maintenance inspection.



WARNING: Do not attempt to open the Maxi Sky 440 portable lift cassette. Only a qualified technician is authorized to open it. Alterations made to the portable lift by someone other than a qualified technician may cause serious injury.

Troubleshooting

Problem	To check
The red “service” light is on and flashing.	<ul style="list-style-type: none"> • Contact your local Arjo representative for maintenance.
The unit starts and stops repetitively.	<ul style="list-style-type: none"> • If the load is greater than the unit’s safe working load, it will not function due to an overload protection on the motor. Batteries are low and need to be changed. Contact your local Arjo representative.
The lift emits a “beep” during use. The unit may stop lifting the patient but can still lower the patient.	<ul style="list-style-type: none"> • Batteries are low and need to be recharged.
Charger indicator (yellow) does not light up when the charger is connected to the lift.	<ul style="list-style-type: none"> • Check that the charger is plugged into a standard electrical outlet, and that the outlet has power. The green indicator light on charger 700.13510.33 confirms the functionality of the charger.
The lift does not work when you press the buttons on the hand control.	<ul style="list-style-type: none"> • If the emergency stop is activated, gently release the emergency button. Check if the buttons on the lift are working. If they are working, the problem may come from the hand control. If they are not working, check the charge on the lift. Check to see if the hand control is plugged in properly into the lift. The hand control may be slightly pulled out from its socket and yet appear as though it is plugged in. Check the connection. If, after testing all of the above, the lift will not operate, contact your Arjo representative.

Labels on the Lift

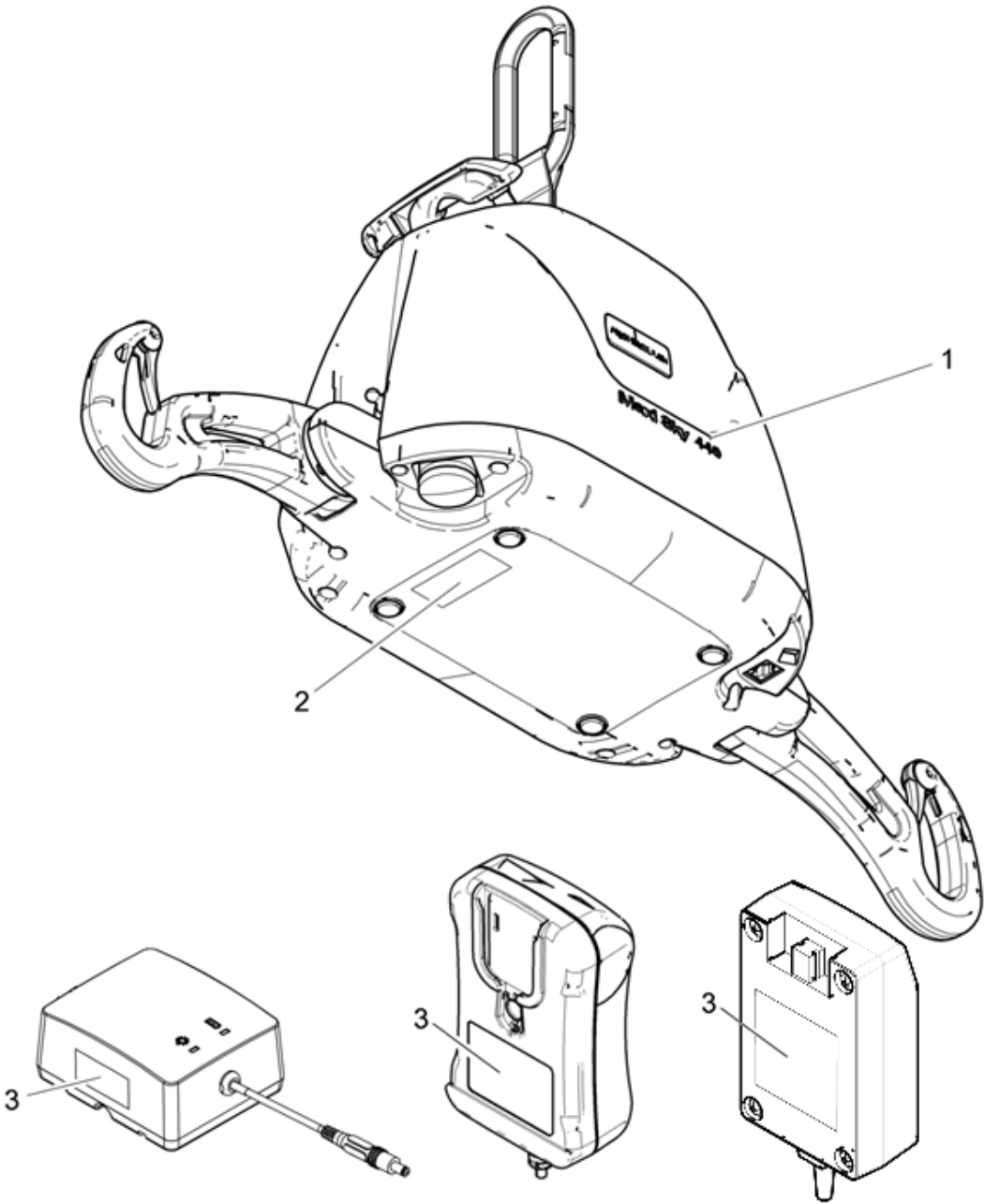

- 1. Product Name
- 2. Serial Number Label
- 3. Charger Information

Wiring Diagram

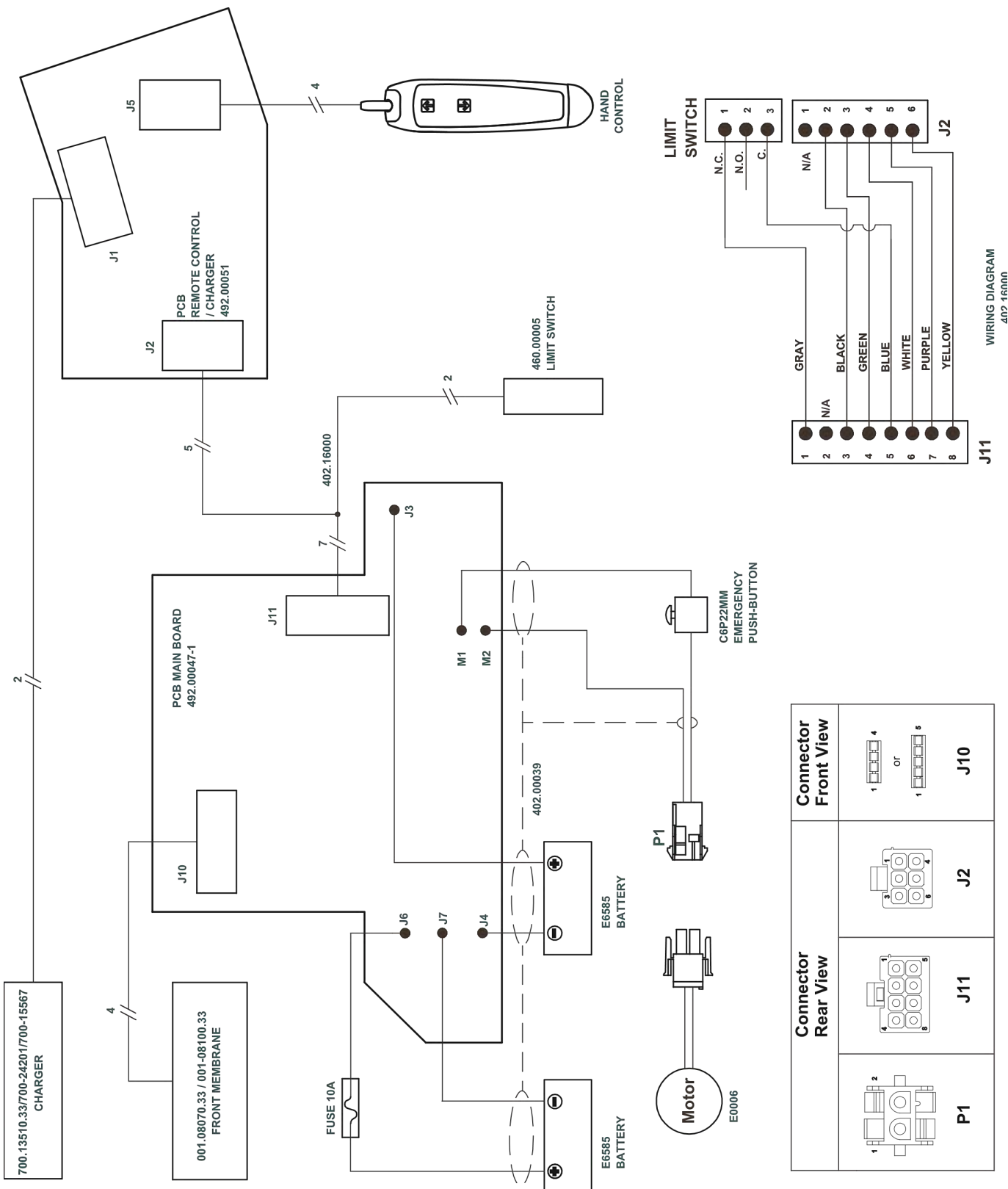

WIRING DIAGRAM
402 16000

Technical Specifications

GENERAL	
Weight, complete	6.5 kg (14.3 lb)
Lifting capacity	200 kg (440 lb)
Strap length	2200 mm (88 in)
Lifting speed	4.3 cm/s (1.7 in/s)
ELECTRICAL	
Duty cycle	Max 10%, 6 min/h, (max. 1 min. continuous)
Rating	24 VDC, 10 A max.
Noise level for either raising or lowering, with or without load	54 dBA max.
Medical equipment	Type BF protection against electrical shock in accordance with IEC 60601-1
BATTERIES AND CHARGER UNIT	
Batteries	Qty: 2 x rechargeable 12 VDC, 2.3 Ah
Battery capacity	Provides up to 30 transfers with a load of 80 kg (176 lb)
Degree of protection – Hand control	700-13860: IPX4 700-13865: IPX7
Degree of protection - Maxi Sky 440	IP21
Lift - protection class - shock prevention	Internally powered equipment
Battery Charger input	100-240 VAC, 50-60 Hz
Battery Charger output	700.13510.33: 27-29 VDC, 1A 700-24201: 28 VDC, 1A 700-15567-B: 24 VDC, 1A
Battery Charger safety protection	Class 2, double insulated
OPERATING CONDITIONS	
Ambient temperature range	10 °C to 40 °C (50 °F to 104 °F)
Relative humidity range	30 % to 75 %
Atmospheric pressure range	700 hPa to 1060 hPa
STORAGE CONDITIONS	
Ambient temperature range	-40 °C to +70 °C (-40 °F to +158 °F)
Relative humidity range	10 % to 100 % incl. condensation
Atmospheric pressure range	500 hPa to 1060 hPa
RECYCLING	
Battery	Sealed lead-acid, rechargeable, recyclable
Package	Recyclable cardboard
The lift	Separated and recycled, according to the European Directive 2002/96/EG (WEEE).

The Maxi Sky 440 is compliant with CAN/CSA-C22.2, CSA-Z323.5.98, IEC 60601-1, UL 60601-1 and ISO 10535.



WARNING: Radio transmitting devices such as mobile telephones, two-way radios, etc., should never be used near the Maxi Sky 440 since they can interfere with the function of the lift. Cables from potentially strong sources of electromagnetic fields should not be placed near the unit.



WARNING: This equipment is not suitable in the presence of flammable anaesthetic mixtures with air or *oxygen*, or with nitrous oxide.

Technical Specifications

Dimensions

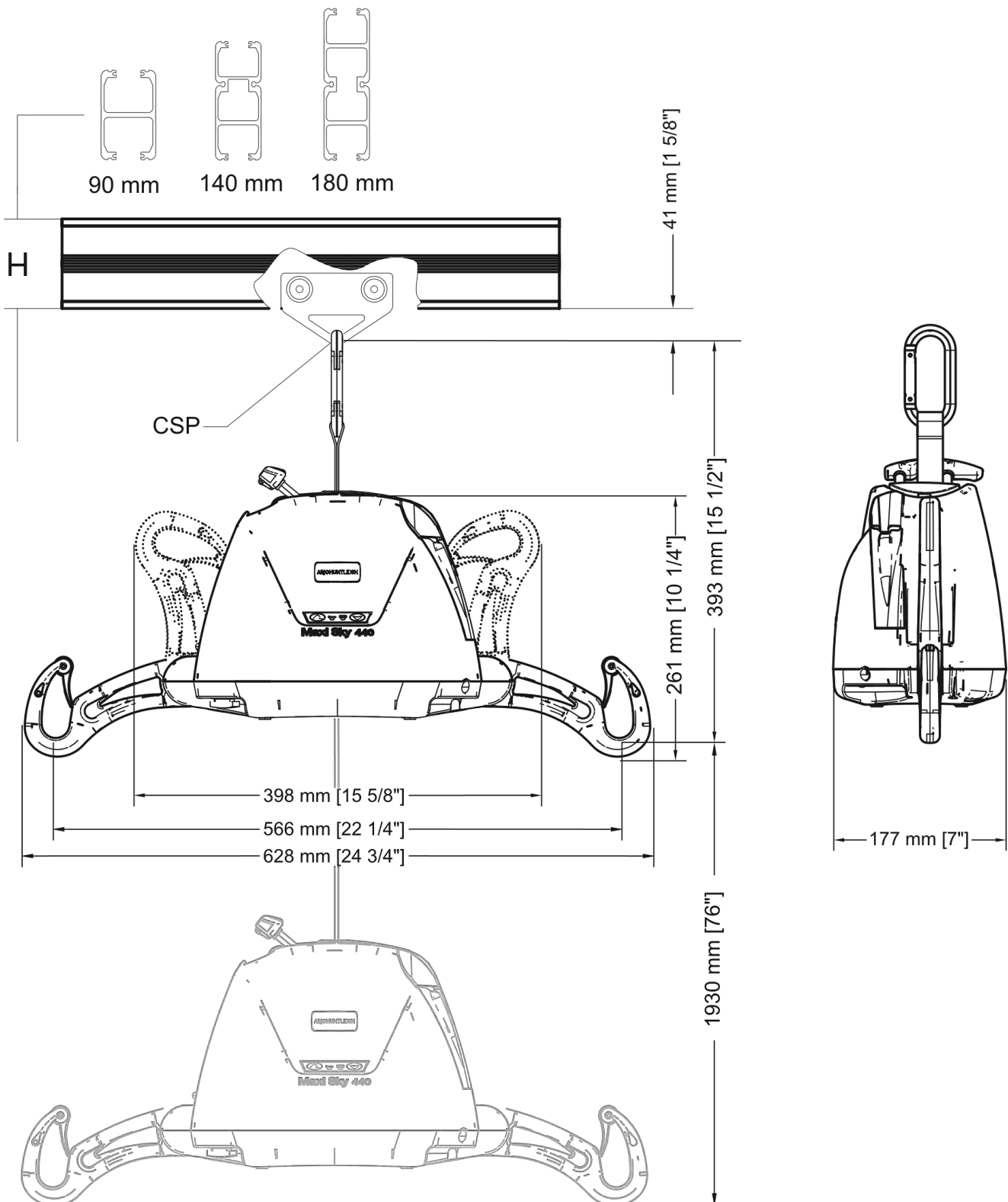

At Arjo, we are committed to improving the everyday lives of people affected by reduced mobility and age-related health challenges. With products and solutions that ensure ergonomic patient handling, personal hygiene, disinfection, diagnostics, and the effective prevention of pressure ulcers and venous thromboembolism, we help professionals across care environments to continually raise the standard of safe and dignified care. Everything we do, we do with people in mind.



ArjoHuntleigh AB
Hans Michelsensgatan 10
211 20 Malmö, Sweden
www.arjo.com

arjo