

**Voyager Duo**  
Instructions for Use

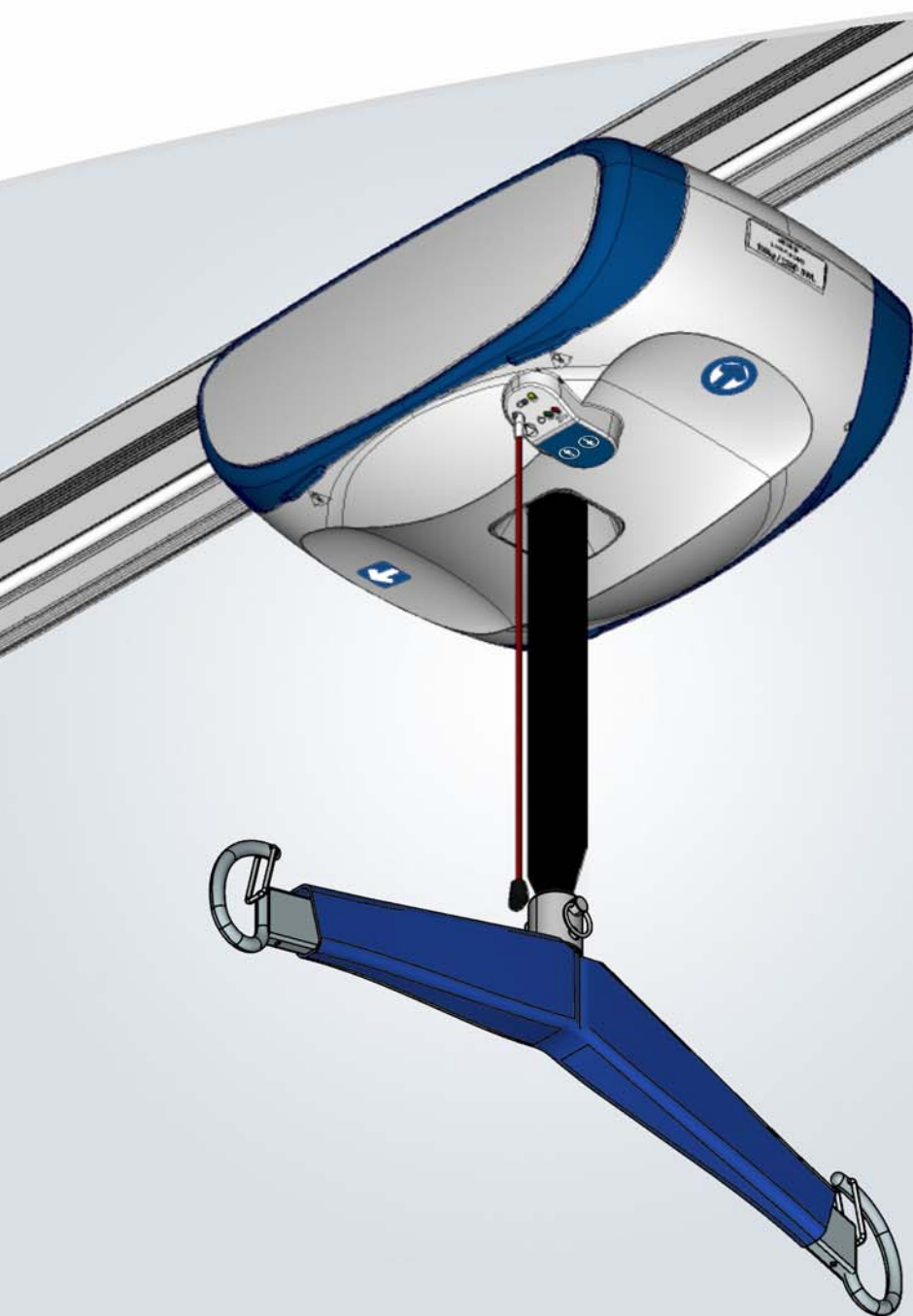

## Design Policy and Copyright

® and ™ are trademarks belonging to the ArjoHuntleigh group of companies.

© ArjoHuntleigh 2011.

As our policy is one of continuous improvement, we reserve the right to modify designs without prior notice.

The content of this publication may not be copied either whole or in part without the consent of ArjoHuntleigh.

# Table of Contents

<b>General Information</b> .....	<b>5</b>
Foreword.....	5
Service and Support.....	5
Manufacturer Information .....	5
Definitions Used in this Manual: .....	6
Intended Use .....	6
Operational Life .....	6
Product Identification.....	6
How to Use this Manual .....	6
Symbols Used.....	7
<b>Safety Instructions</b> .....	<b>8</b>
General Instructions.....	8
Addendum for Rail System Other than KWIKtrak .....	8
Safe Working Load.....	8
Important Safety Directions .....	8
Shock Prevention .....	9
Fire and Explosion Prevention .....	9
Human and Environmental Safety Practices.....	9
Environmental Advice.....	9
Battery and Battery Charger Safety Practices.....	9
Homecare Environment Considerations.....	10
<b>Part Designation</b> .....	<b>11</b>
Voyager Duo Ceiling Lift and Charger Station for KWIKtrak Rail System .....	11
Hand Control.....	12
Chargers .....	12
Overheat Protection Device .....	12
Battery Information.....	12
<b>Accessories</b> .....	<b>13</b>
<b>How to Use the Voyager Duo Ceiling Lift</b> .....	<b>14</b>
Controls and Features .....	14
Emergency Lowering.....	14
Emergency Stop (red cord) .....	14
Return to Charge (RTC) .....	15
Emergency Brake.....	15
Indicator Lights .....	15
Spreader Bar Attachment.....	15
Compatible Slings .....	16
<b>Loop Sling Application</b> .....	<b>17</b>
Slings Selection .....	17
Attaching the Sling to the Spreader Bar.....	17
Positioning the Patient.....	17
Attachement Methods .....	18
Transferring the Patient .....	19
Lifting Patient from a Seated Position .....	19
Lowering Patient to a Seated Position .....	20
Lifting Patient from a Supine Position .....	20
Lowering a Patient to a Supine Position.....	20
Using Stretcher Frames and Stretchers.....	20
<b>Use of Accessories</b> .....	<b>21</b>
How to Use the Exchanger .....	21
How to Use the Turntable .....	21
How to Use the Gate.....	22

# Table of Contents

---

Using the PPP Function (Pre-Programmed Positions).....	22
<b>Voyager Duo Programming .....</b>	<b>23</b>
Changing the Speed of Movement .....	23
Adjusting the Spreader Bar Height .....	24
Enable/Disable Return to Charge (RTC) .....	25
<b>Care and Maintenance.....</b>	<b>26</b>
Preventive Maintenance Schedule .....	26
User Inspections.....	26
Inspections by an Authorized Service Technician .....	27
Cleaning the Lift.....	29
Strap Inspection .....	30
Handling and Storage.....	30
Batteries Replacement.....	30
Sling Inspection and Care .....	30
Annual Inspection .....	30
<b>Troubleshooting.....</b>	<b>31</b>
<b>Labels on the Lift .....</b>	<b>33</b>
<b>Technical Specifications .....</b>	<b>34</b>
Lift Dimensions .....	35
<b>Electromagnetic Compatibility .....</b>	<b>36</b>
Electromagnetic Compliance .....	36
Electromagnetic Emissions.....	36
Electromagnetic Immunity.....	37

# General Information

Thank you for buying the Voyager® Duo from ArjoHuntleigh.

Your Voyager Duo lift is part of a series of quality products designed specially for home care, nursing homes and other health care uses.

We are dedicated to serving your needs and providing the best products available along with training that will bring your staff maximum benefit from every ArjoHuntleigh product.

Contact us if you have any questions about the use or maintenance of your ArjoHuntleigh product.

## Foreword

Please read this manual in its entirety before using your Voyager Duo lift. The information in this manual is crucial to the proper operation and maintenance of the Voyager Duo. It will help protect your product as well as ensure that the equipment performs to your satisfaction.

Lifting and transferring a person always presents a potential risk. Some of the information in this manual is important for your safety and must be read and understood to help prevent injuries.

**WARNING: Injuries can be attributed to the use of inadequate parts. Use only parts designated by ArjoHuntleigh on your Voyager Duo.**

**WARNING: Unauthorized modifications on any ArjoHuntleigh product, including rail system installations, may affect its safety. ArjoHuntleigh will not be held responsible for any accidents, incidents or deficiencies of performance that occur as a result of any unauthorized modification to its products.**

## Service and Support

A service routine must be performed on your Voyager Duo lift by ArjoHuntleigh trained service staff. This will ensure the safety and good function of your product. See “Care and Maintenance” section.

Please contact your local ArjoHuntleigh agent if you need more information, want to report an unexpected event or notice any changes in the performance of your lift, or if you need any help in setting up, using or maintaining your Voyager Duo. The agent can offer support and service programs to maximize the long-term safety, reliability and value of the product.

Contact your local ArjoHuntleigh agent for replacement parts.

Additional copies of this manual can be bought from your local ArjoHuntleigh agent. When ordering, include the *Instructions for Use* part number (see front page) and the product part number.

## Manufacturer Information

This product has been manufactured by:

ArjoHuntleigh AB  
Verkstadsvägen 5  
241 38 Eslöv  
Sweden

☎: +46 (0) 10-335 4500

☎: +46 (0) 413-138 76

🌐: [www.ArjoHuntleigh.com](http://www.ArjoHuntleigh.com)

# General Information

## Definitions Used in this Manual:

### WARNING:

**Means:** Failure to understand and follow these instructions may result in injury to yourself and others.

### CAUTION:

**Means:** Failure to follow these instructions may cause damage to the product.

### NOTE:

**Means:** This is important information regarding the correct use of the equipment.

## Intended Use

The Voyager Duo lift is designed for lifting patients in a homecare setting, at nursing homes and other assisted living centers. Patient transfers must be done under the supervision of trained caregivers in accordance with the instructions found in this manual.

The product must only be used for the reasons stated above. It must be installed by ArjoHuntleigh authorized personnel and in accordance with local codes.

## Operational Life

The product is designed and tested for a useful life of seven (7) years or 10,000 transfers, whichever comes first. It is subject to preventative maintenance as specified in the "Care and Maintenance" section.

Time equivalence between the number of transfers versus the number of years is made clear in the table in Fig. 1.

Transfers per Day	Years (10,000 transfers)
4	7
6	4.5
8	3.5

Fig. 1

**WARNING:** The manufacturer cannot ensure full safety for a ceiling lift or an accessory of which the life span has been exceeded. Wear may cause the breakage of a part and lead to a patient fall.

The red indicator light on the ceiling lift will blink when it is about halfway to its useful life, and again to indicate the end of the useful life period.

The operating life of this product corresponds directly to the safe operating time period before a complete overhaul is required. Aging of the ceiling lift, frequency of use (transfers per day), the weight of the patient and maintenance frequency are factors that have an impact on the Voyager Duo's life span. A transfer is defined as the displacement of a patient from one point to another. A transfer cycle includes a lifting and a descending action.

The expected operational life for fabric slings and fabric stretchers is approximately two years from purchase date. This life expectancy only applies if the slings and stretchers have been cleaned, maintained and inspected in accordance with the ArjoHuntleigh Sling Application Guide, the *Instructions for Use* and the "Preventive Maintenance Schedule".

The expected life for other consumable products, such as batteries, fuses, lamps, slings, straps and cords is dependent upon the care and usage of the equipment concerned. Consumables must be maintained in accordance with published *Instructions for Use* and the "Preventive Maintenance Schedule".

## Product Identification











The unit's identification number (specification, model, serial number) appears on a silver nameplate attached to the lift's plastic housing (see Fig. 3).



## How to Use this Manual

**WARNING:** Do not attempt to use this equipment without fully understanding the information contained in this manual. A misuse of this unit may lead to a patient fall and to injuries.

Keep this manual with the lift and refer to it as required.

## Symbols Used

General Symbols	Key to symbols
	This symbol is accompanied by a date to indicate the date of manufacture and by the address of the manufacturer.
	This symbol indicates the products comply with the medical device directive 93/42/EEC.
	This symbol indicates the approval of the Canadian Standards Association.
	This symbol is accompanied by the manufacturer's catalogue number.
	This symbol is accompanied by the manufacturer's serial number.
	This symbol refers to the <i>Instructions for Use</i> .
	This symbol indicates "separate collection" for all batteries and accumulators as per the WEEE Directive.
	This symbol indicates a risk of pinching.
<b>SWL</b>	Safe Working Load represents the maximum load the lifter is rated for safe operation.
<b>IP<sub>N<sub>1</sub></sub>N<sub>2</sub></b>	Degree of protection provided by enclosure. N <sub>1</sub> : Ingress of particles, N <sub>2</sub> : Ingress of water.
	Direct current.
	Alternating current.

General Symbols	Key to symbols
	This symbol indicates a type BF applied part.
	This symbol locates the emergency stop system on the lift cassette.
	This symbol locates the emergency lowering system on the lift cassette.

Charger Related Symbol	Key to symbol
	This symbol indicates a class II electrical equipment: term referring to electrical equipment in which protection against electric shock does not rely on basic insulation only.

# Safety Instructions

## General Instructions

**WARNING:** The Voyager Duo lift is for transferring patients only. Do not use the lift for any other purpose. It could get damaged and the safety of the patient may be compromised.

**WARNING:** Always place the sling around the patient according to the instructions enclosed. Failure to do so may result in injuries to you or to others.

**CAUTION:** Do not drop the ceiling lift. This could cause internal damage that is not easily seen. If the ceiling lift is suspected to be damaged, contact your local ArjoHuntleigh agent.

**NOTE:** ArjoHuntleigh ceiling lifts are specifically designed for KWIKtrak rail systems, ArjoHuntleigh slings and accessories.

## Addendum for Rail System Other than KWIKtrak

ArjoHuntleigh could have adapted this ceiling lift to be used with a rail system other than KWIKtrak.

If this is the case, an addendum (001-14250-\*\*) \* must be supplied with this *Instructions for Use*, please refer to the addendum for informations relevant to that specific rail system.

The addendum provides important informations relative to:

- Safe Working Load
- Rail System Limitations
- description for specific parts.

Before using the Voyager Duo lift, make sure it is compatible with accessories installed on that rail system.

**NOTE:** Before using the Voyager Duo lift on a rail system other than KWIKtrak, make sure you have read and understood the addendum supplied with this *Instructions for Use*.

## Safe Working Load

The Voyager Duo lift has been designed with two settings with regards to the safe working load:

- 100 kg (220 lb);
- 200 kg (440 lb): default configuration.

The ArjoHuntleigh installation team is equipped to change the SWL of your lift to 100Kg if needed.

**WARNING:** The Voyager Duo lift is intended to be used for patients whose weight is within a specified safe working load. Do not attempt to lift more than the lowest weight limit indicated on the following:

- the rail system;
- the “maximum load” label on the Voyager Duo lift;
- on the spreader bar;
- on the accessories;
- on the sling.

Surcharge of any of these elements may lead to a patient fall and to injuries.

## Important Safety Directions

Always ensure that:

- The ceiling lift is installed and put into service by an authorized ArjoHuntleigh contractor or installer.
- This product is used by trained staff.

**WARNING:** Before using the Voyager Duo lift, a clinical assessment of the patient’s suitability for transfer must be carried out by a qualified health professional. A transfer conducted when it should not can degrade the patient’s health condition.

- Special consideration is taken when transferring a patient who is connected to electrodes, catheters or other medical devices.
- Violent impact during transfers is avoided.
- The sling is not damaged, torn or frayed.
- The lifting procedures outlined in this manual are followed.
- All controls and safety features are used only according to the rules specified in this manual. Never attempt to force a control or button on the lift.
- The charger is not stored in a shower, bath or other areas with high humidity.

\*. Last two characters varies according to the manual language.



# Safety Instructions

- The sling straps are in good condition and properly fastened.
- The daily maintenance is carried out before using the lift.
- Any precautionary or instruction labels that cannot be easily read are replaced.

**WARNING: ArjoHuntleigh warns of possible strangulation risks related to the lifting strap, hand control cable and emergency pull cord. Necessary precautions should be taken to prevent these.**

**WARNING: This product contains small parts that might present a severe danger if swallowed or inhaled.**

**CAUTION: Keep all components of the lift clean and dry to avoid a malfunction of the device.**

**CAUTION: Excessive exposure of the hand control to water (or other liquid) could cause malfunction of the device.**

## Shock Prevention

- Do not touch or use a lift with bare conductors or a damaged power cord. If this is the case, contact your local ArjoHuntleigh agent immediately.
- Do not expose the unit to water or moisture.
- Check nameplate for input voltage and frequency requirements. These requirements differ by country. Do not attempt to use the lift in an area that has a different voltage and frequency requirement.
- Do not attempt to expose, service or repair the lift, batteries or charger. If any unit is malfunctioning, contact your local ArjoHuntleigh agent.
- Read batteries and charger instructions thoroughly before using or storing them.

## Fire and Explosion Prevention

- Do not place or store the batteries under direct sunlight or near a heat source.
- Do not expose the batteries or battery charger to flames.
- Do not use the charger in the presence of flammable anaesthetic gases.
- Do not short circuit the battery terminals.

## Human and Environmental Safety Practices

- Should a battery casing crack and cause contents to come in contact with skin or clothing, rinse immediately with plenty of water.
- If contents come in contact with the eyes, rinse immediately with plenty of water and seek medical attention.
- Inhalation of the contents can cause respiratory irritation. Provide fresh air and medical attention.
- For recycling and disposal of the batteries, the rules according to the WEEE directive (Waste of Electronic and Electrical Equipment) as well as local laws and regulations must be followed. If not they may explode, leak and cause personal injury. When returning batteries, insulate their terminals with adhesive tape. Otherwise, the residual electricity in used batteries may cause fire or explosion. Environmental Advice below shows the symbols for disposal and recycling.

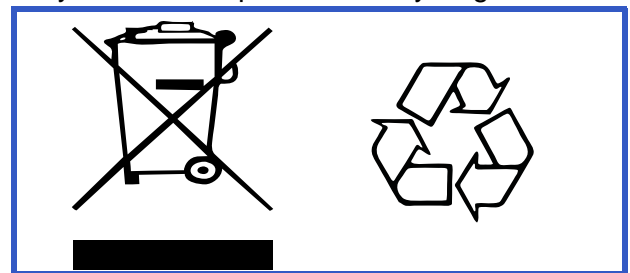

Fig. 2

## Environmental Advice

When disposing of any items associated with the equipment, contact the appropriate local authorities for information.

## Battery and Battery Charger Safety Practices

**NOTE: The following instructions is important for the safe use of the batteries.**

**WARNING: Do not operate the charger unit with a damaged cord or if the unit has been dropped or damaged.**

**Do not bend the power cord by force, or place a heavy object on it. This will damage the cord and may cause fire or electrical shock.**

- Do not expose the battery charger or connector to water.
- To avoid bodily injury, do NOT crush, puncture, open, dismantle or otherwise mechanically interfere with the batteries.
- Be careful not to drop the batteries.

# Safety Instructions

---

- Only use the charger that has been supplied with the product.
- Do not charge the batteries in an unventilated area.
- The charger must not be covered or exposed to dust.

## Homecare Environment Considerations

**WARNING: The Voyager Duo is not intended to be operated by children. Serious injuries could occur.**

**NOTE: Rigorous cleaning actions are needed when the Voyager Duo is near animals. Pet hair trapped inside the device (through the strap opening) can reduce the product's performance.**

## Voyager Duo Ceiling Lift and Charger Station for KWIKtrak Rail System

Refer to the addendum for rail systems other than KWIKtrak.

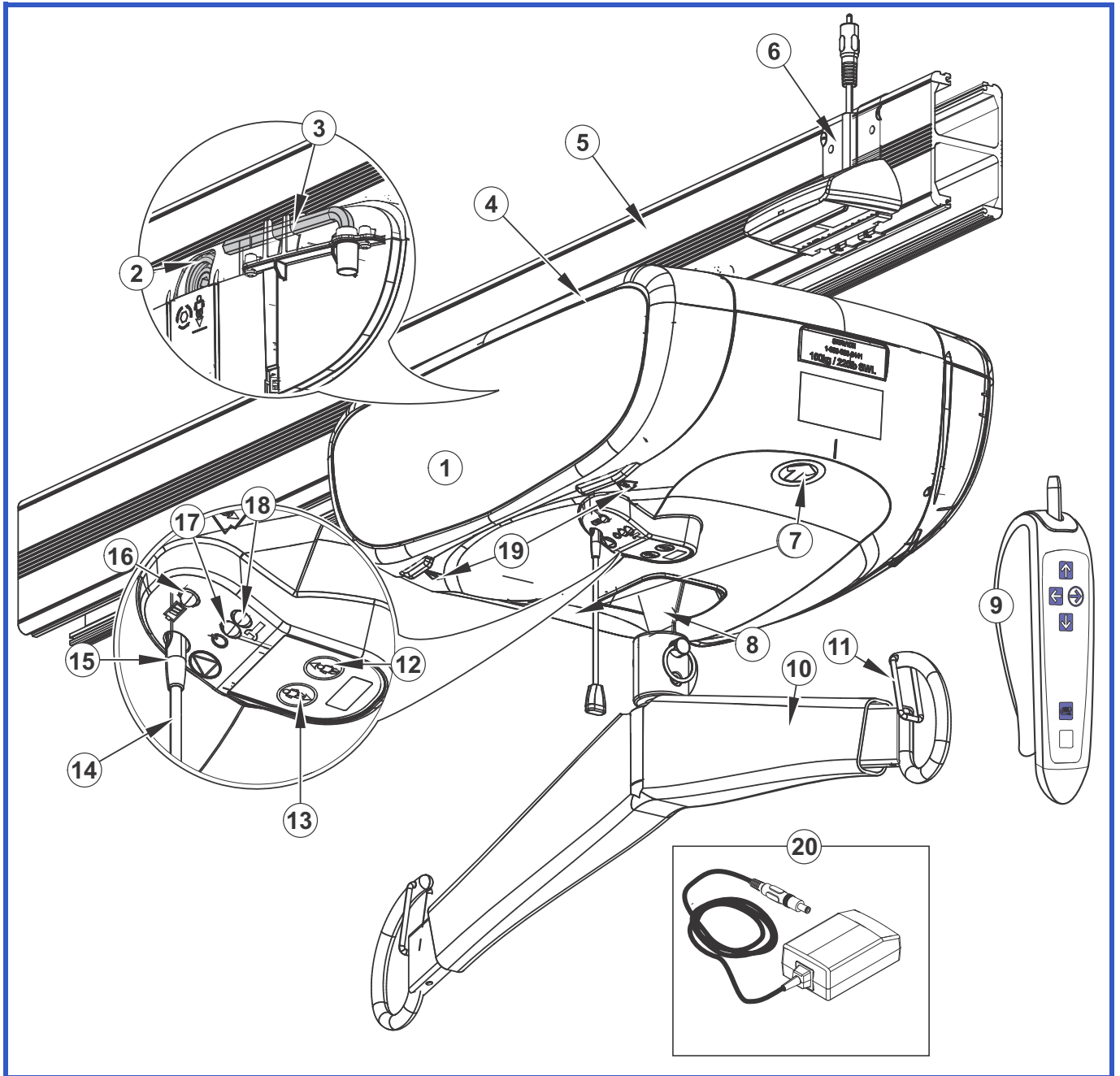

Fig. 3

### Legends

- |     |                              |     |   |
|-----|------------------------------|-----|---|
| 1)  | Ceiling lift                 | 12) | Up button                                     |
| 2)  | Emergency lowering mechanism | 13) | Down button                                   |
| 3)  | Allen key                    | 14) | Red emergency pull cord                       |
| 4)  | Side panel                   | 15) | Reset switch plastic insert                   |
| 5)  | KWIKtrak Rail                | 16) | Yellow charging light                         |
| 6)  | Charging station             | 17) | Green power light                             |
| 7)  | Travel direction arrows      | 18) | Red maintenance/overload light                |
| 8)  | Strap                        | 19) | Indicators for emergency lowering side access |
| 9)  | Hand Control                 | 20) | Wall-adapted charger                          |
| 10) | Spreader bar                 |     |   |
| 11) | Safety latch                 |     |   |

# Part Designation

## Hand Control

The Voyager Duo's hand control unit is used to operate the ceiling lift. Each function is described in Fig. 4. The UP and DOWN buttons raise or lower the spreader bar. With the four-function model, the LEFT and RIGHT buttons activate a lateral motor to move the lift along the rail. If you have a two-function model, the lift must be moved manually.

The PROGRAMMING MODE button allows you to modify the functions of the lift. Refer to the "Voyager Duo Programming" section for more information.

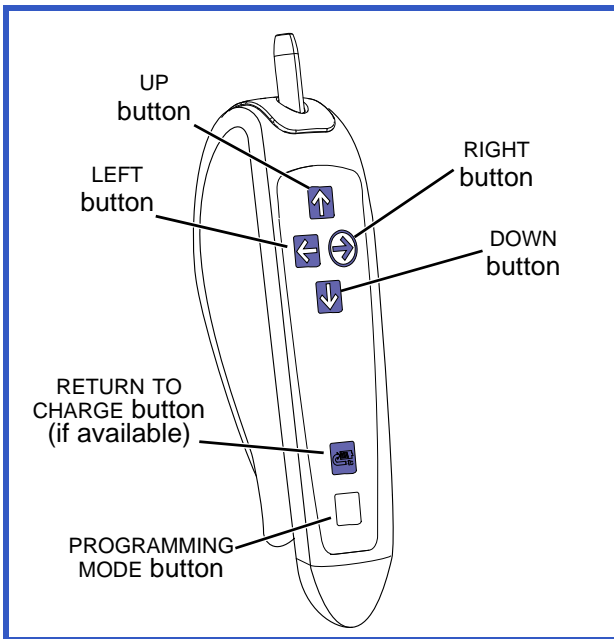

Fig. 4

## Battery Information

The Voyager Duo uses two 12 volts sealed lead-acid batteries. This battery type requires being fully charged at all time.

Batteries life is variable (2-3 years) and is influenced by: frequency of use, frequency of charging, temperature of operation/storage and storage time.

To prolong the batteries life, recharge them before the Low Battery indicator signal shows up.

To recharge the batteries, place the unit under the charging station. Check the battery status indicator to confirm that the batteries are charging.

**NOTE: Batteries will not recharge when the emergency stop is applied.**

**NOTE: The unit will not lift or lower when it is in charging position.**

See Fig. 5 for a graph illustrating the relationship between the number of lifts versus the load being lifted.

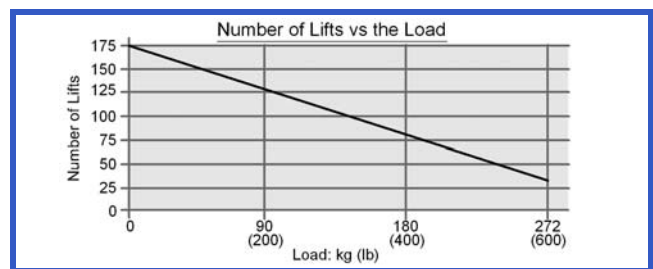

Fig. 5

## Chargers

The Voyager Duo units are equipped with a wall-adapted charger that can be customized to fit the AC voltage outlets where they are sold (see Fig. 3).

## Overheat Protection Device

The Voyager Duo units are equipped with a safety system to prevent a misuse of the lift. If the lift is used above the amount specified by the duty cycle, a detection system will block the lifting of a load until the temperature of the transmission cools down. In the meantime, it will still be possible to activate the horizontal displacement and down functions. When the overheat protection is engaged, the red light will stay on during the cooling period. In addition, a buzzer will sound if the UP button is pressed. The cooling period is between 10 to 30 minutes depending on ambient conditions.

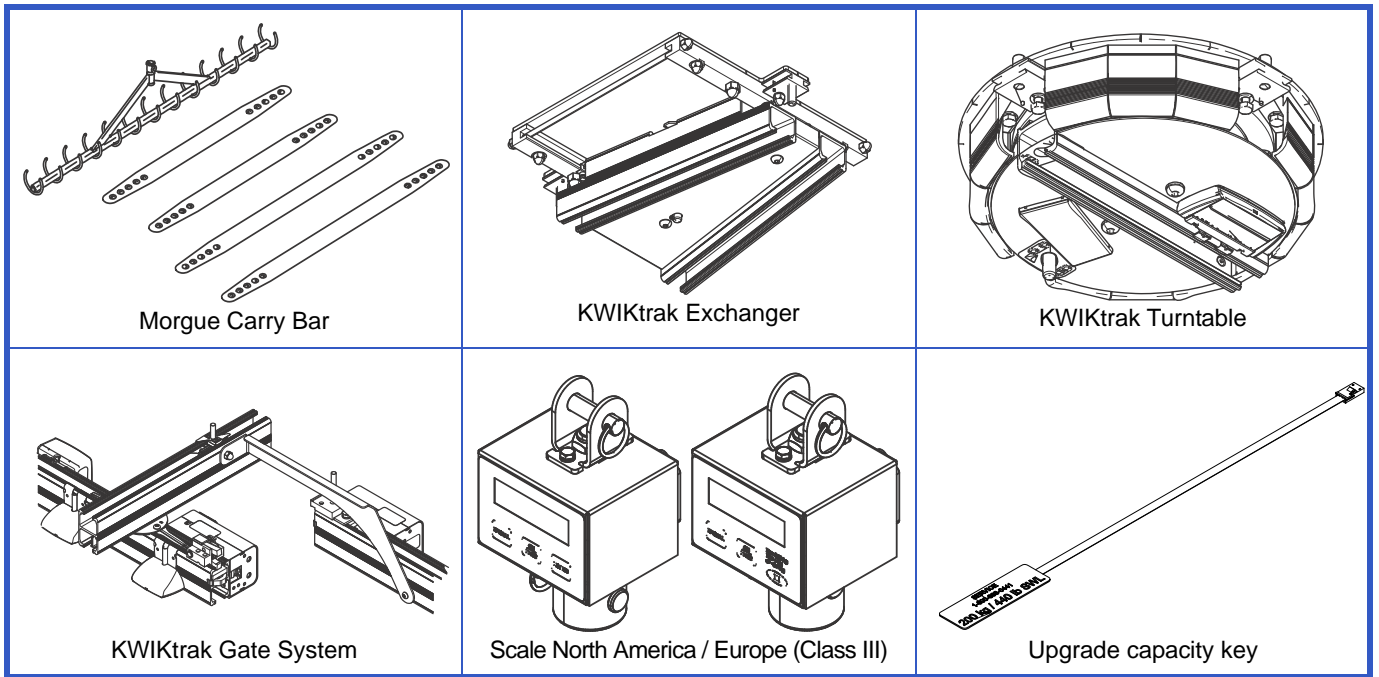

Fig. 6

Refer to your local ArjoHuntleigh agent for ordering.

# How to Use the Voyager Duo Ceiling Lift

## Controls and Features

### Emergency Lowering

In the unlikely event of an electrical failure, the Voyager Duo lift has an emergency manual lowering feature.

**CAUTION: The emergency lowering feature is to be used only in case of emergency.**

If the lift malfunctions when a patient is being transferred, the emergency lowering device provides a safe way of getting the patient down onto a chair, bed or wheelchair.

Procedure:

- 1) Pull the red emergency cord.

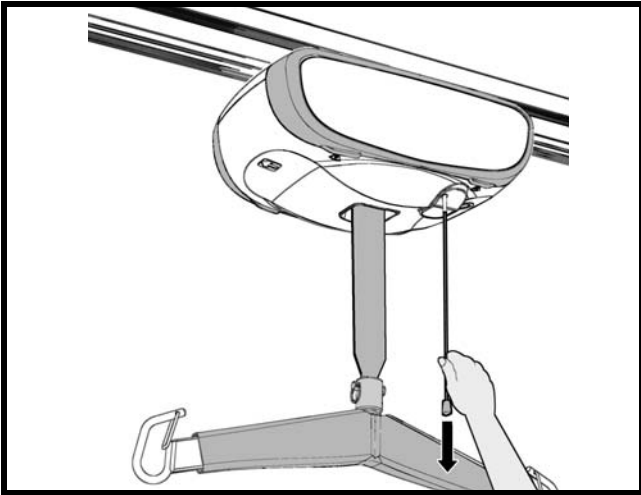

Fig. 7

- 2) Access the emergency lowering system

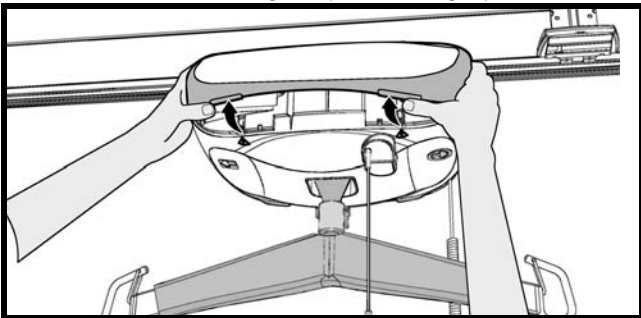

Fig. 8

- 3) Remove the Allen key.

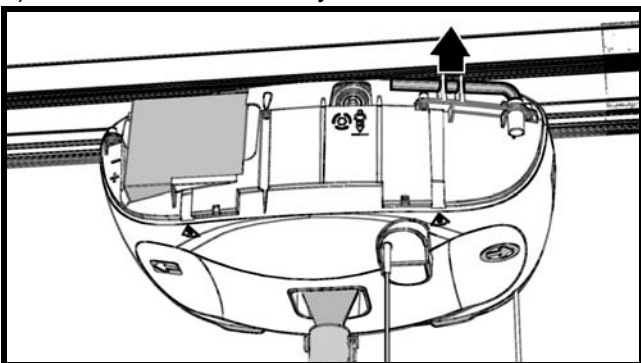

Fig. 9

- 4) Turn the Allen key counter-clockwise to slowly lower the patient.

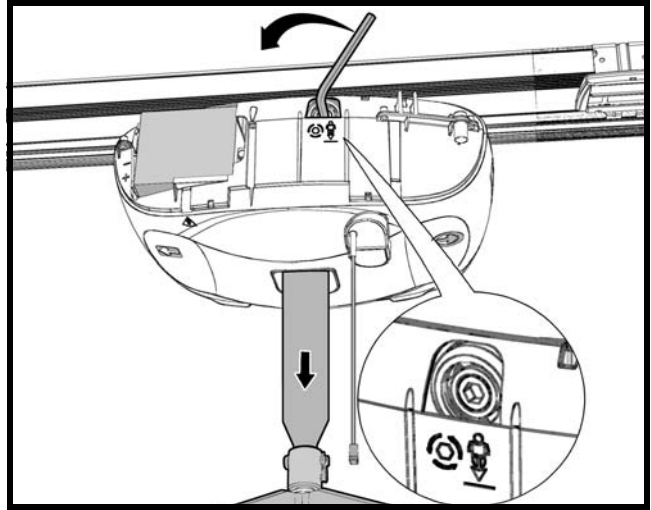

Fig. 10

Once the patient is lowered and secure within a chair, bed or wheelchair, call a qualified technician to inspect the lift.

### Emergency Stop (red cord)

The emergency stop can be activated at any time to stop the functioning of the lift.

- 1) To stop the lift in any emergency, gently pull the red emergency cord until you hear a “click” (see Fig. 11 - A). You will notice that:
  - The reset switch’s plastic insert, at the very top of the red cord, has descended (see Fig. 11 - B);
  - The green power light is off;
  - The patient begins to descend slowly when the emergency stop is activated, which is normal.

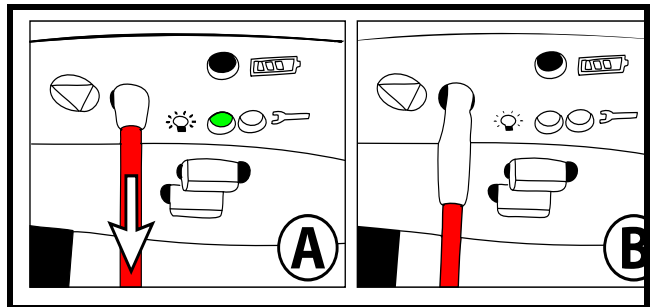

Fig. 11

**CAUTION: Do not pull the red emergency cord with excessive force. If the cord is jerked too hard, the lift may become inoperable.**

- 2) To reactivate the lift, push up on the reset switch’s plastic insert (for units equipped with infrared hand controls pull the red emergency cord again). A green light confirms that the Voyager Duo lift is on and ready for use.



# How to Use the Voyager Duo Ceiling Lift

## Return to Charge (RTC)

The RTC function is disabled by default. To activate this function, please refer to the “Voyager Duo Programming” section.

To engage the RTC function, press on the return to charge button on the hand control for 3 seconds. The spreader bar will raise all the way up to avoid any obstacles during the run. When the lift is at the charging station, the spreader bar lowers by itself to the preselected height so as to be easily accessible.

The RTC function is not an automatic transfer function. A safety weight detector is included in you device to prevent the use of the function when patient is present in sling.

**WARNING: DO NOT make use of the RTC function where there is a patient in the lift, as this could cause injuries to the patient.**

**NOTE: You can stop the return to charge at any time by pressing any button on the hand control or pulling on the red emergency cord.**

**WARNING: Extra care is required when transferring a patient that weighs 20 kg (45 lb) or less. The weight detector within the unit that prevents the RTC from functioning when a patient is in the lift can only detect a minimum load of 20 kg (45 lb). Use of the RTC function in such conditions may lead to the patient hitting obstacles along the path and may cause injuries to patient.**

**WARNING: Constant surveillance is required when using the RTC function to prevent the spreader bar from hitting someone/ something along the path.**

## Emergency Brake

The emergency brake is a safety feature that blocks the descent in the unlikely event of a transmission or motor failure.

**WARNING: After an incident has occurred and the brake was deployed, never attempt to use any function of the lift. This may disengage the brake and make the patient fall.**

The emergency brake is intended for single activation and therefore can only be used once. Call your ArjoHuntleigh agent to arrange for the unit to be replaced.

The emergency lowering device cannot be used when the emergency brake has deployed.

## Indicator Lights

The lift and the charging system have many indicator lights. Refer to following table to understand their significance for the proper use and comprehension of the lift.



POWER INDICATOR		
(Green) 	Flashing	Low batteries.
	Solid	Lift cassette is on, ready to use.
BATTERIES STATUS		
(Yellow) 	Flashing	Charging.
	Solid	Charged.
MAINTENANCE		
(Red) 	Flashing	Contact your local ArjoHuntleigh technician in order to perform the necessary maintenance inspection.
	Solid	Lift is in “service mode” or is under overheat protection.
CHARGING		
Charging station indicator	Solid green	Clip-on charging station power is on
	Solid red	Problem with charger; do not use the charger.

Fig. 12

## Spreader Bar Attachment

The spreader bar features an attachment which allows the caregiver to change it in a few steps without using any tools.

### Attaching the Spreader Bar to the Lift

**WARNING: Spreader bars must only be installed by a trained person. Before every use, always ensure that the strap is properly attached and that the attachment is secured with the split ring.**

- 1) Insert the strap end onto the spreader bar attachment.
- 2) Insert the clevis pin through the attachment and the loop at the end of the strap.
- 3) Secure the clevis pin with the split ring.

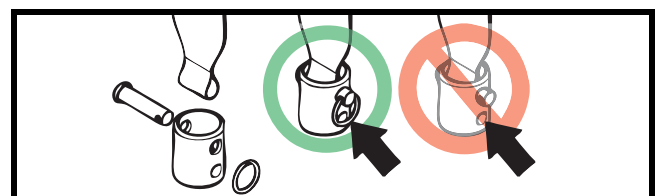

Fig. 13

# How to Use the Voyager Duo Ceiling Lift

## Compatible Slings

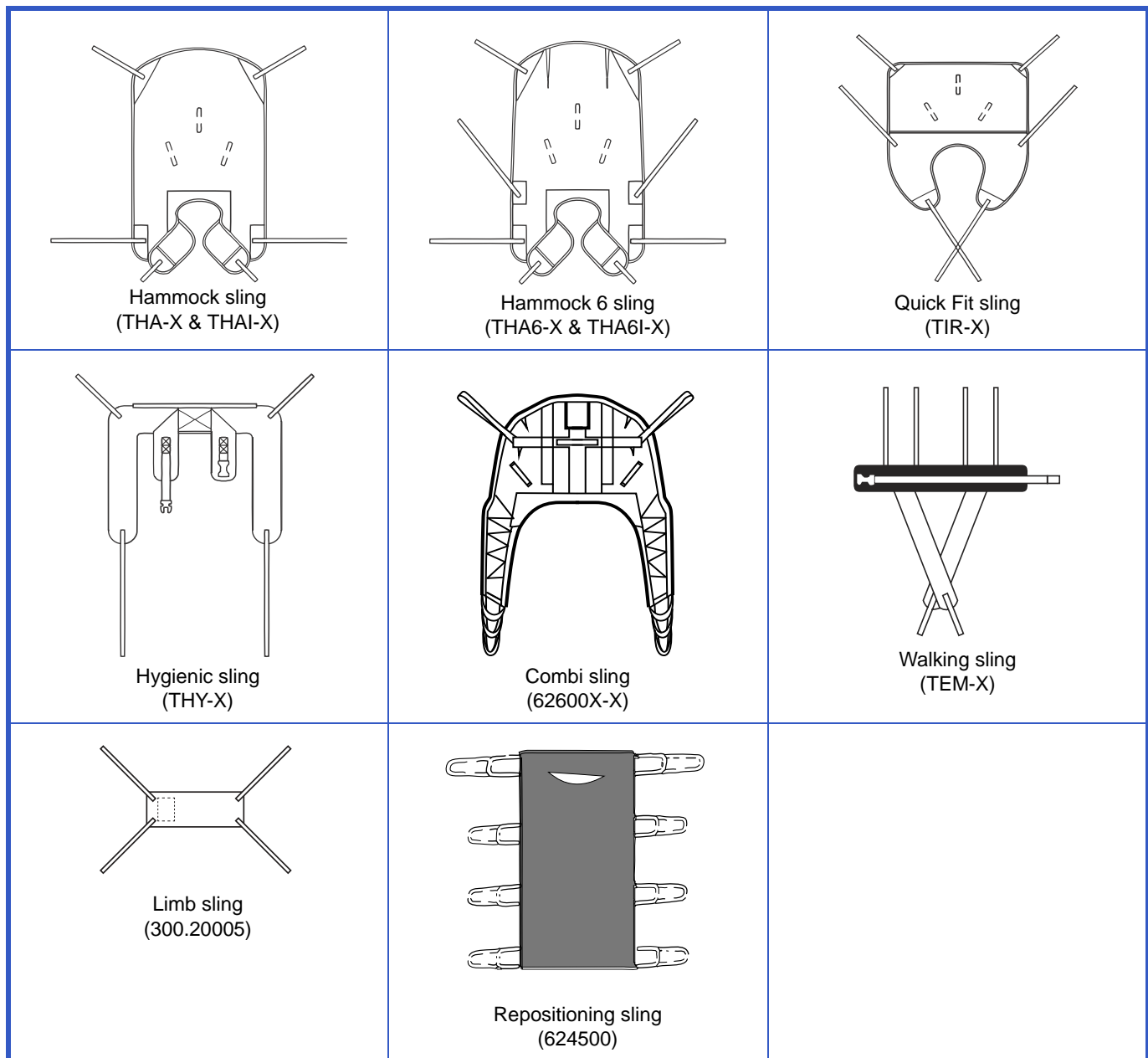

Fig. 14



# Loop Sling Application

## Slings Selection

The spreader bar that is attached to the Voyager Duo lift determines what slings can be used to transfer a patient.

Loop slings must be used with the 2-point spreader bar.

All slings are color coded for size by having a different colored edge binding or attachment strap coloring:

- Grey or Teal - Extra Extra Small - XXS
- White or Brown - Extra Small - XS
- Red - Small - S
- Yellow - Medium - M
- Green - Large - L
- Blue - Extra Large - XL
- Terracotta - Extra Extra Large - XXL

The correct size sling will be able to support the patient's shoulders during the transferring procedure.

ArjoHuntleigh offers the option of a head support for many of our slings if it is considered necessary for a particular patient. A range of special purpose slings are available as accessories. For these or for special size slings, contact your ArjoHuntleigh agent.

**Note:** If ArjoHuntleigh *Flites* slings (disposable) are to be used with the Voyager Duo lift, then always refer to the separate *Flites Instruction for Use* in conjunction with current *Instructions for Use*.

## Attaching the Sling to the Spreader Bar

Place the attachment loops onto the hooks.

Make sure the loops are positioned correctly and that the latches are closing the hooks as shown below.

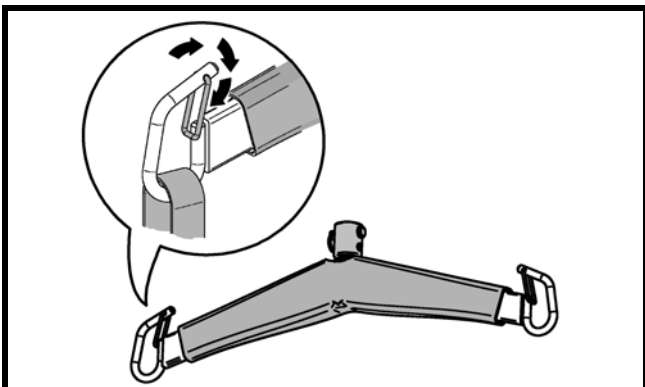
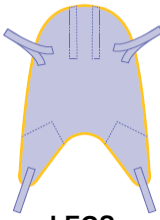







Fig. 15

## Positioning the Patient

The specific sling loops chosen determine the position of the patient. Different loop combinations can be used to allow the patient to be lifted and transferred in positions ranging from semi-reclined to seated.

BODY POSITION ACCORDING TO SELECTION OF LOOP STRAPS			
SHOULDERS	SHOULDERS	LEGS	HIPS*
			
	3	1	1
	2	1	1
	1	1	1
	1	1	2

\*Hip loops only available on THA6i model

**NOTE:** Slings with more loops allow additional alternative positions.

# Loop Sling Application

## Attachement Methods

Once the loop sling has been fitted around the patient, it can be configured in three ways. With each of the three methods described below, it is necessary to first connect each shoulder loop of the sling to both sides of the spreader bar.

### Attachments Points

The attachment point designation shown here are only for the purpose of the explanations below.

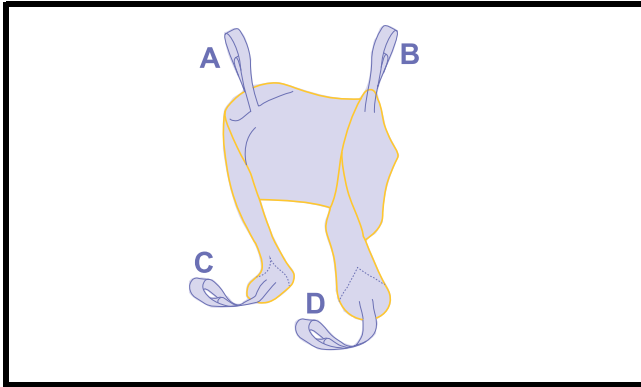

Fig. 16

### Method 1 - Cross-through

(Legs closed with crossing straps)

This method is recommended for most general transfer.

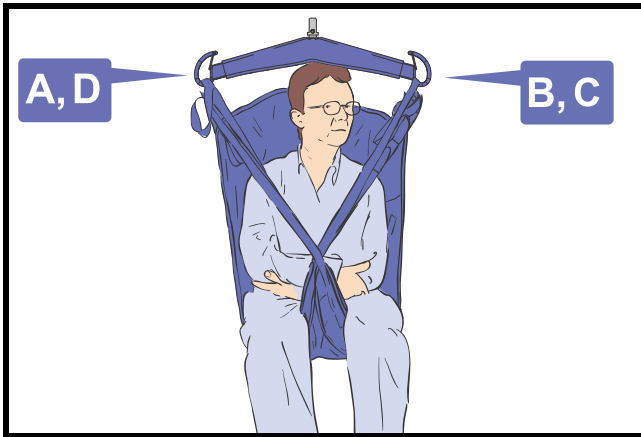

Fig. 17

### Method 2 - Hammock

(Bridge, legs closed)

This method can provide a comfortable cradle for amputee patient.

It is also a useful method for patients with contractures, making it difficult to bring a sling strap between the legs.

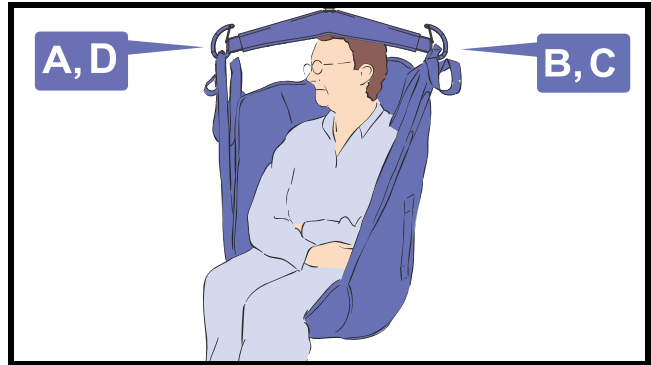

Fig. 18

**WARNING: Method 2 might not be suitable for confused, combative or erratic patients as they can fall forward and get injured.**

### Method 3 - Abduction

(Legs opened with non-crossing straps)

In this method, legs are held in abduction which is convenient for toileting and hygiene care.

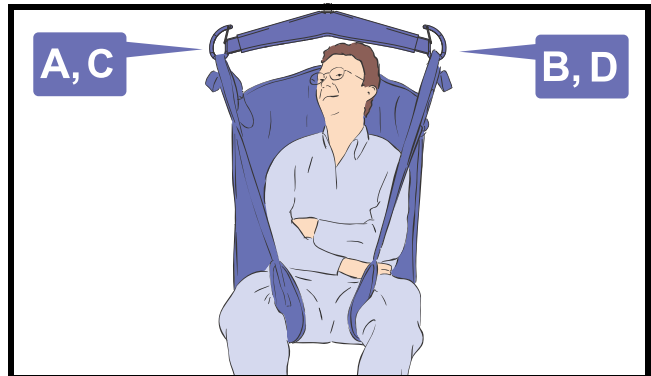

Fig. 19

**WARNING: Method 3 might not be suitable for patients with no upper body control as they can slide down and almost out of the sling.**

# Loop Sling Application

## Transferring the Patient

Before using the Voyager Duo ensure that:

- Always carry out the items marked as “Before every use” in the “Preventive Maintenance Schedule” before using the lift.
- To avoid the patient swinging excessively during lifting, the lift strap should be as vertical as possible, immediately prior to the lift.

**WARNING:** A patient should never be left unattended during a transfer. Certain safety features can only be accessed by the caregiver and patient could get stuck in the event of a malfunction.

**WARNING:** The lift must never be operated by the patient. In the unlikely case of a failure, the patient might get stuck in the unit.

**WARNING:** Always hold the spreader bar when near a patient. The spreader bar could hit the patient resulting in injury.

**WARNING:** Before raising the patient, always make sure the sling is not caught on any obstructions (for instance, the wheelchair brakes or armrests). Sling catching in such obstructions could result in a patient fall.

**WARNING:** Always confirm that the sling remain attached as the weight of the patient is gradually taken up. A wrongly fastened attachment could detach resulting in patient fall.

**WARNING:** Make sure that the spreader bar is correctly attached to the lift. An unsecured spreader bar attachment may lead to patient fall.

**WARNING:** Make sure the intended route of travel is clear to prevent the patient from bumping any obstruction.

**CAUTION:** Do not attempt to pull the cassette along the rail using the hand control cable. This will damage the cable and eventually ruin the function of the hand control.

## Lifting Patient from a Seated Position

- 1) Place the sling around the patient so that the base of the sling sits slightly below the tail bone. A MaxiSlide® or MaxiTube® positioning aid can be used to assist with placement of the sling.



Fig. 20

- 2) Ensure that the head support area of the sling is behind the head covering it.
- 3) Pull each leg strap under the thigh so that it emerges on the inside of the thigh.

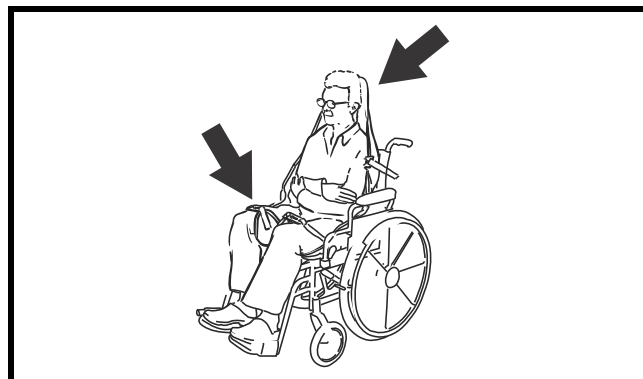

Fig. 21

- 4) Approach the patient with the lift, ensure that:
  - The spreader bar is at or just below shoulder level.
  - The spreader bar is close enough to be able to fix all the sling loops onto the spreader bar hooks.
- 5) Connect the shoulder loops, and then the leg section using one of the three methods previously described.



Fig. 22

# Loop Sling Application

- 6) If necessary, lower the spreader bar a little further.
- 7) Raise the patient.
- 8) Turn the patient to face the direction of travel, and keep at a normal chair height.
- 9) Proceed with the transfer.

## Lowering Patient to a Seated Position

- 1) Once arrived at destination, lower the patient down onto the new location.
- 2) When the patient's body weight is fully supported, detach the sling.
- 3) Move the lift away from the patient.
- 4) Remove the sling from under the patient.

## Lifting Patient from a Supine Position

**WARNING: When lifting a patient from a bed, make sure that the bed safety side is installed to prevent the patient from falling.**

- 1) Roll the patient onto their side.
- 2) Fold the sling in half and place on the bed land marking it, along the back of the patient so that the base of his spine is aligned with the base of the sling, making sure the sling extends to the top of the patient's head.

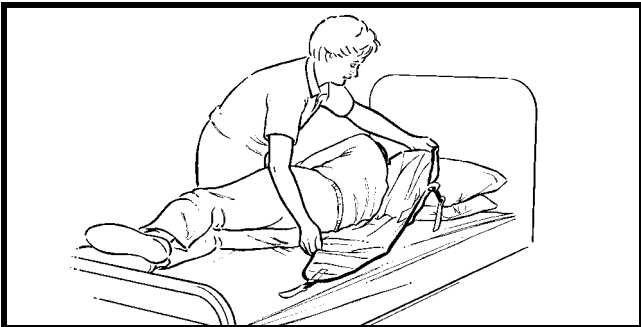

Fig. 23

- 3) Roll the patient back onto the sling and then slightly further in the opposite direction, so that the folded part of the sling can be unfolded.
- 4) If possible, slightly raise the head of the bed.
- 5) Approach the patient with the lift. Ensure that the spreader bar is close enough to be able to fix all the sling loops onto the spreader bar hooks.
- 6) Connect the shoulder loops, and then the leg section using one of the three methods previously described.
- 7) Raise the patient.

- 8) Turn the patient to face the direction of travel, and keep at a normal chair height.
- 9) Proceed with the transfer.

## Lowering a Patient to a Supine Position

- 1) Once arrived at destination lower the patient down onto the new location.
- 2) When the patient's body weight is fully supported, detach the sling.
- 3) Move the lift away from the patient.
- 4) Remove the sling from under the patient.

## Using Stretcher Frames and Stretchers

If any of the ArjoHuntleigh patient stretcher frames and stretchers are to be used with the Voyager Duo lift, always refer to the separate relevant stretcher frame and stretcher operating instructions supplements before use.

# Use of Accessories

## How to Use the Exchanger

**Note:** Following section applies only for *KWIKtrak* Rail System.

An exchanger allows the Voyager Duo unit access from one care area to another. Make sure that the lift is on by checking that green power indicator is lit.

Move the lift to the activation station and release the button on the hand control. Listen for a beep, then wait while the exchanger changes the path (see Fig. 24).

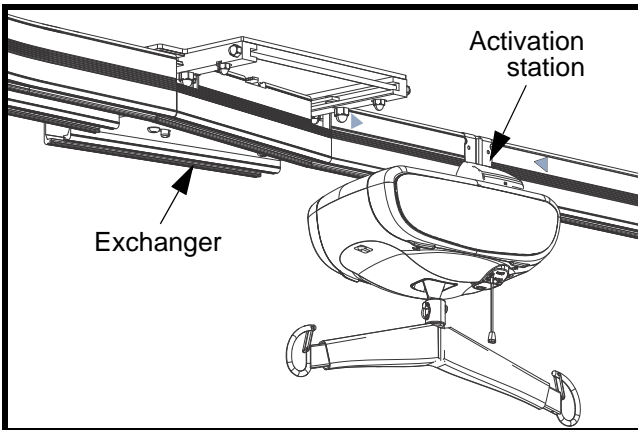

Fig. 24

Move the lift through the exchanger (see Fig. 25).

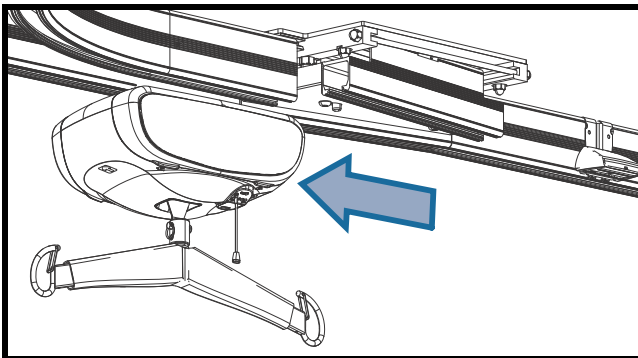

Fig. 25

If the exchanger fails to operate automatically, or if there is an emergency situation, manually engage the quick-release located underneath the exchanger (see Fig. 26). While holding it in the open position, slide the plate over to the new location, being careful not to place your hand or fingers in the path of the sliding plate.

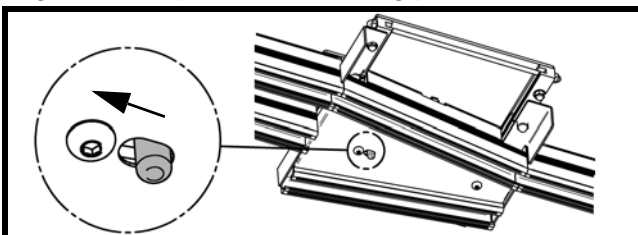

Fig. 26

Release the quick-release button and move the lift through the exchanger.

## How to Use the Turntable

**Note:** Following section applies only for *KWIKtrak* Rail System.

Turntables enable the lift to change route in a multi-directional rail system. Make sure that the lift is on by checking that the green power indicator is lit.

Move the lift to the activation station and release the button on the hand control. Listen for a beep, then wait while the turntable changes the path (see Fig. 27).

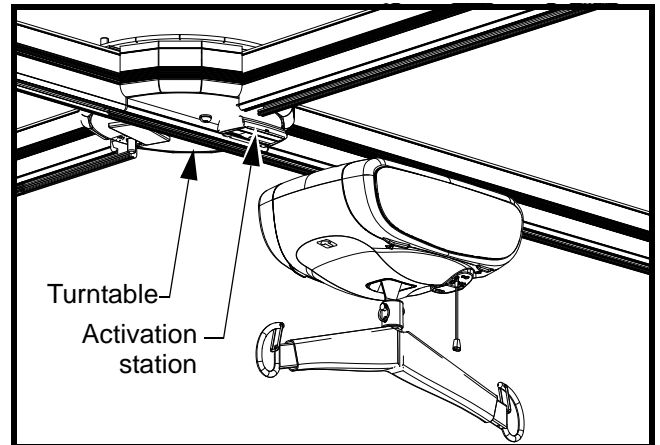

Fig. 27

Move the lift out from the turntable.

If the turntable fails to operate automatically, or if there is an emergency situation, manually engage the quick-release located underneath the turntable (see Fig. 28). While holding it in the open position, turn the plate over to the new location, being careful not to place your hand or fingers in the path of the rotating plate.

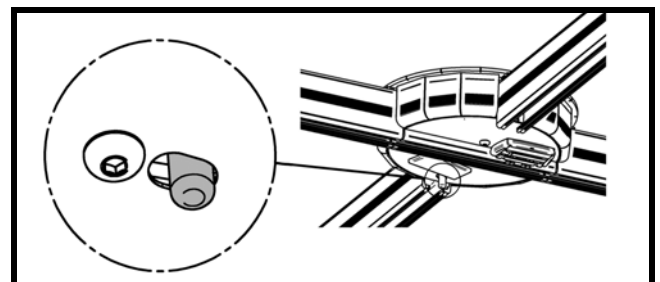

Fig. 28

Release the quick-release button and move the lift through the turntable.



# Use of Accessories

## How to Use the Gate

The Gate is a security device which blocks the access between an X-Y rail system and a fixed rail system to prevent the lift from falling out of the rail when these two systems are not aligned.

### Exiting the Gate

Move the lift in the X-axis to the extremity of the traversal rail in which the Gate is installed on the side of the traversal rail. The lift will be automatically in contact with the activation station.

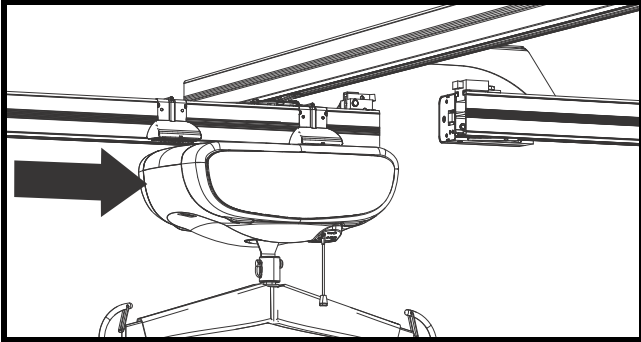

Fig. 29

Move both, the lift and the traversal rail in the Y-axis, to align the traversal rail with the oncoming rail. This action will be detected by the Gate, locking the two rails together, permitting the lift to pass through.

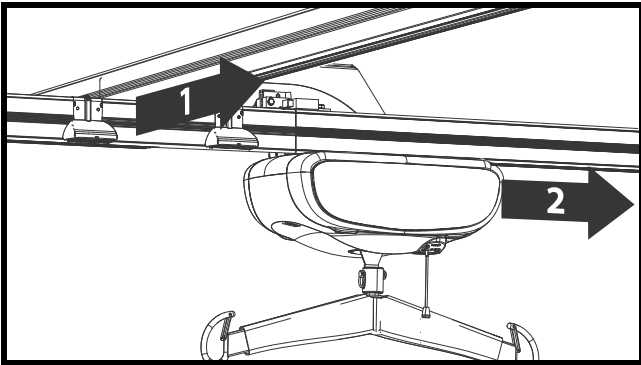

Fig. 30

NOTE: The traversal rail will remain in the locked position, in order to release the traversal rail refer to the "Entering the Gate" section.

### Entering the Gate

When entering the X-Y system from the oncoming rail, the traversal rail will be in place. Pass the lift through the Gate.

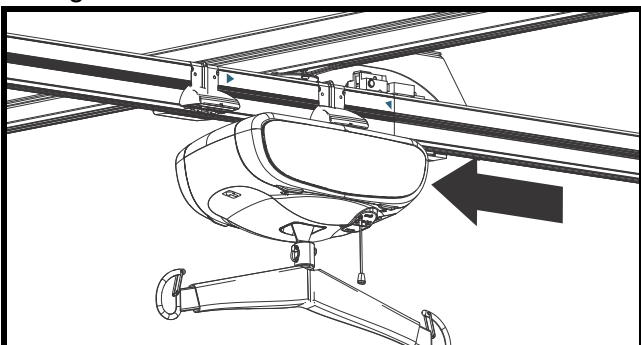

Fig. 31

When the lift has passed the deactivation station, the Gate will release, permitting the traversal rail to move in the Y-axis.

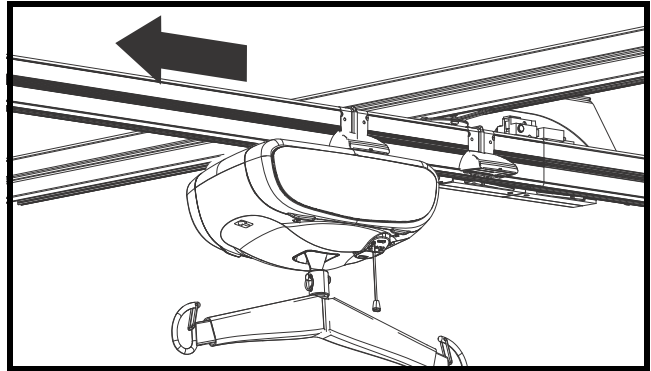

Fig. 32

## Using the PPP Function (Pre-Programmed Positions)

**Note: This function can only be activated by a qualified technician.**

- 1) Using the pre-programmed positions allows the unit to detect stations (positions) located along the rail path. The unit will go to the indicated position by using the hand control.
- 2) To do so, indicate to the unit the desired position to go. For an example, to go to the third station push three times on the PROG button followed by the direction (LEFT or RIGHT buttons).

Then the unit goes by itself to the requested station and stay on hold.

If the position you asked for is not correct, you may stop the lift at any time by pressing any button on the hand control. From this position, reprogram the lift to the new desired position. Count the number of stations from where you are and indicate the direction to go.

# Voyager Duo Programming

The Voyager Duo can be programmed so that the user can easily adjust the speed of the horizontal movement, the spreader bar height and the return to charge parameters of the ceiling lift.

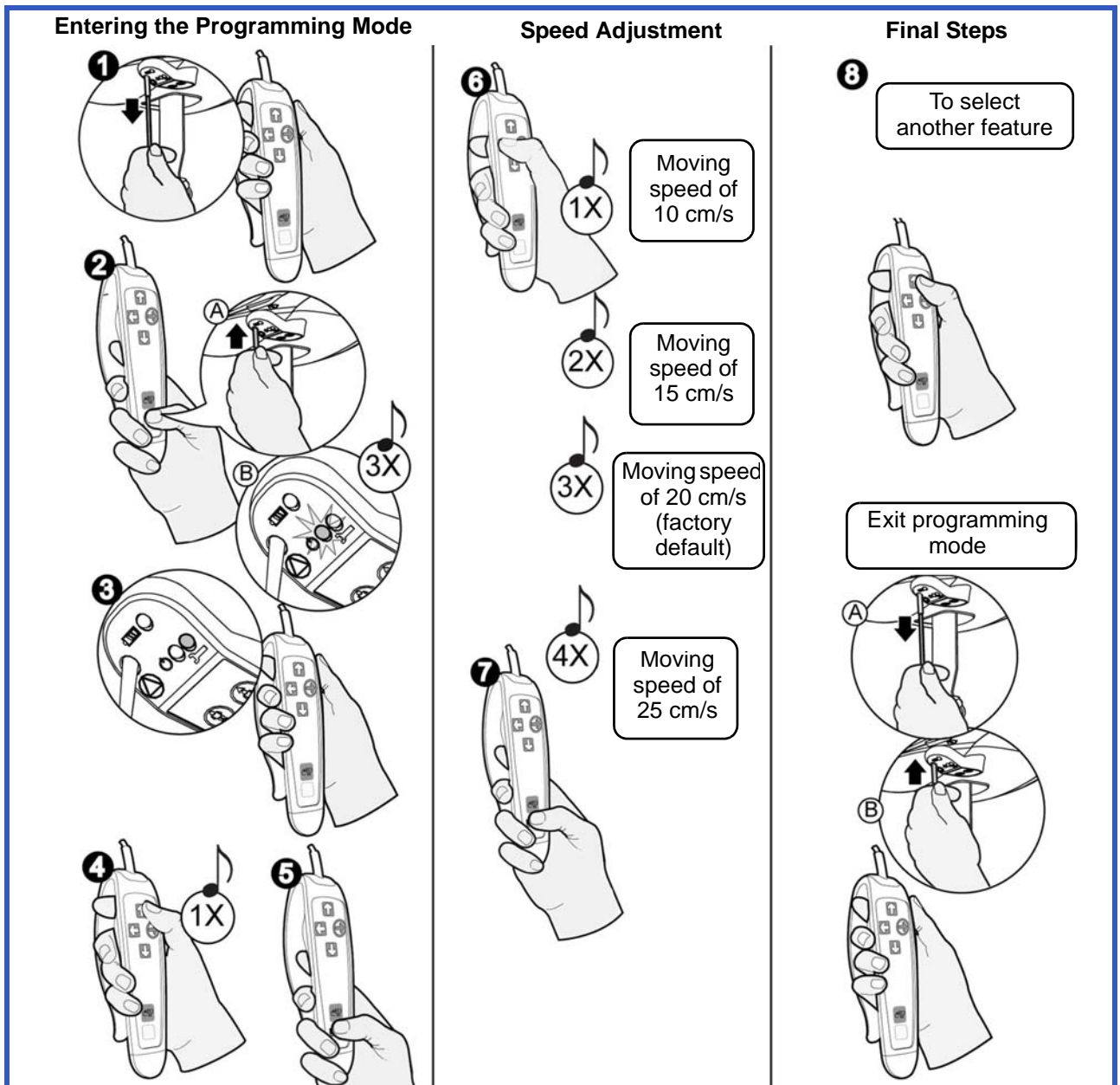

Fig. 33

## Changing the Speed of Movement

- 1 Turn the ceiling lift off by pulling on the red cord. The green LED will turn off.
- 2 Press the PROG button on the hand control. At the same time, push up on the reset switch plastic insert. The green light will flash, and you will hear three beeps.
- 3 The red LED will then illuminate. You can now release the PROG button.
- 4 Press the UP button once (you will hear one beep) for speed adjustment feature.
- 5 Now press the PROG button to confirm the selection.
- 6 Using the LEFT button, select one of four predetermined speeds.
- 7 Now press the PROG button to confirm the selected speed.
- 8 Press UP to continue within the programming mode, or to return to regular mode, pull on the red cord, then push up on the reset switch plastic insert.

# Voyager Duo Programming

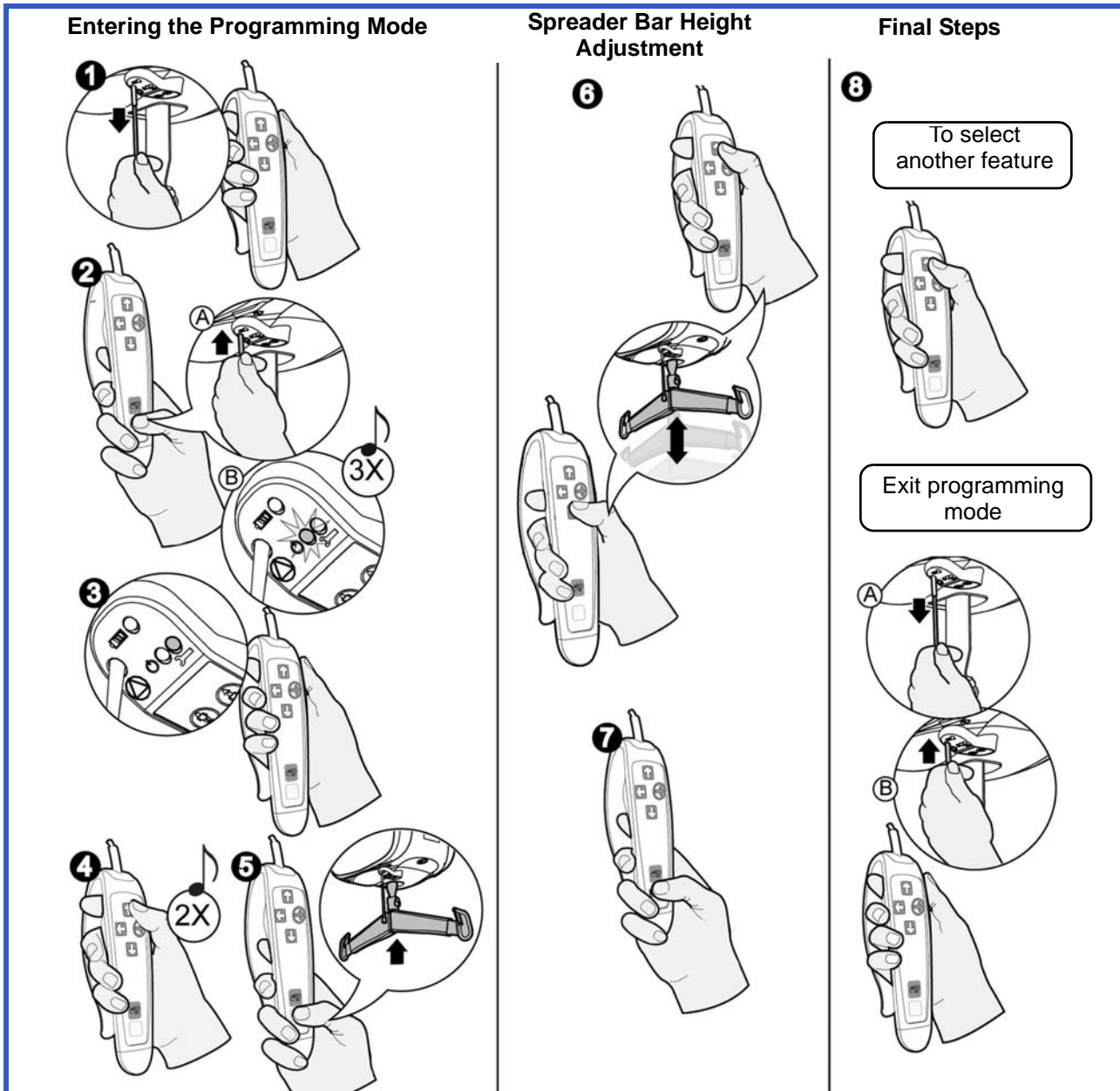

Fig. 34

## Adjusting the Spreader Bar Height

- ❶ Turn the ceiling lift off by pulling on the red cord. The green LED will turn off.
- ❷ Press the PROG button on the hand control. At the same time, push on the reset switch plastic insert at the top of the red cord. The green light will flash, and you will hear three beeps.
- ❸ The red LED will then illuminate. You can now release the PROG button.
- ❹ Press twice the UP button (you will hear two beeps) to change the spreader bar height.
- ❺ Now press the PROG button to confirm the selection.
- ❻ The strap will begin winding up. Once it is completely wound, press the UP and DOWN buttons to set the height the spreader bar's rises to once it is sent to the charging station.
- ❼ Now press the PROG button to confirm the selected height.
- ❽ Press UP to continue within the programming mode, or to return to regular mode, pull on the red cord, then push up on the reset switch plastic insert.



# Voyager Duo Programming

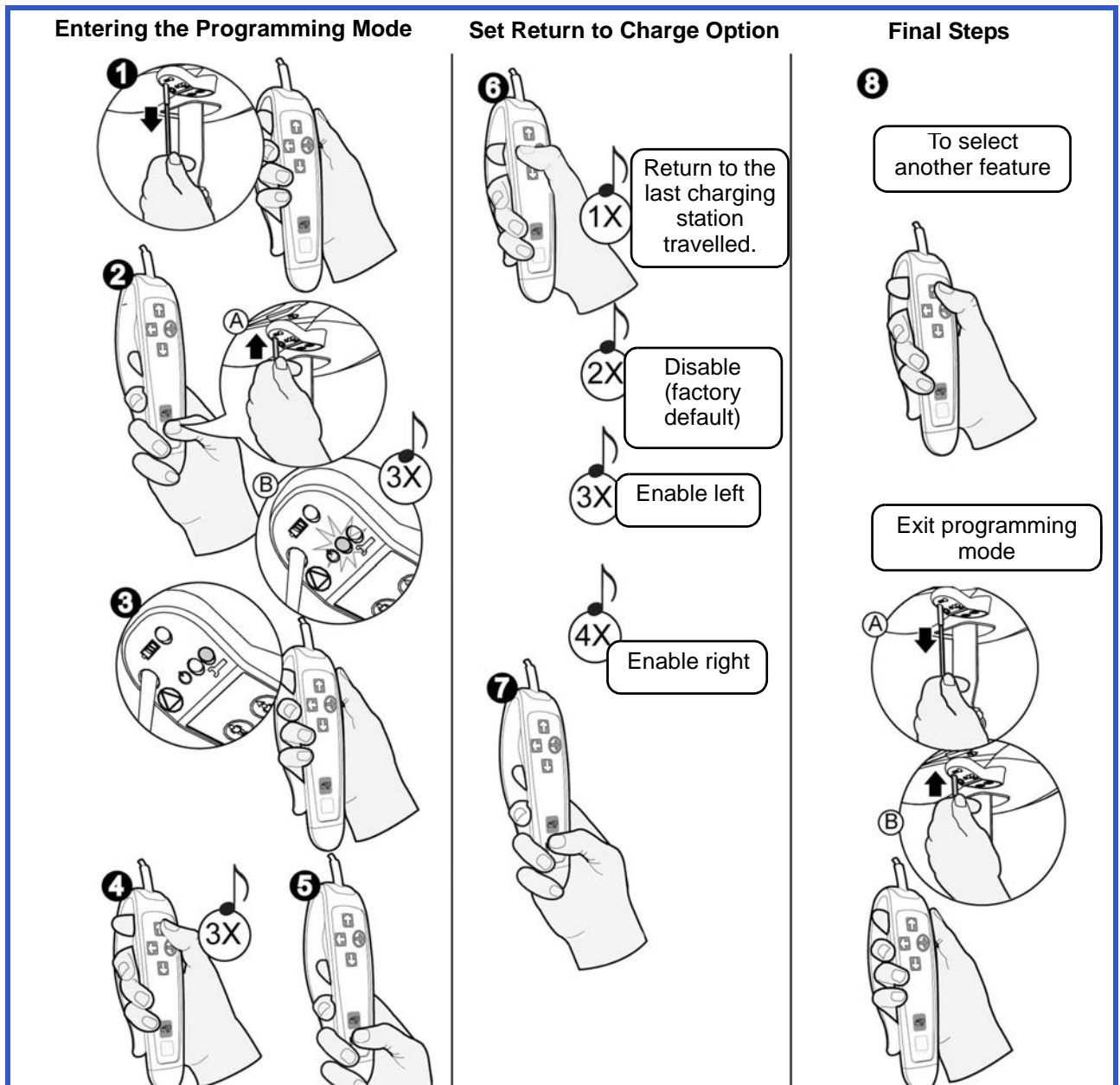

Fig. 35

## Enable/Disable Return to Charge (RTC)

- 1 Turn the ceiling lift off by pulling on the red cord. The green LED will turn off.
- 2 Press the PROG button on the hand control. At the same time, push up on the reset switch plastic insert. The green light will flash, and you will hear three beeps.
- 3 The red LED will then illuminate. You can now release the PROG button.
- 4 Press three times on the UP button (you will hear three beeps) to enable/disable the RTC.
- 5 Now press the PROG button to confirm the selection.
- 6 Using the LEFT button, select one of the four predetermined selection.
- 7 Now press the PROG button to confirm the selected return to charge.
- 8 Press UP to continue within the programming mode, or to return to regular mode, pull on the red cord, then push up on the reset switch plastic insert.

# Care and Maintenance

## Preventive Maintenance Schedule

The equipment is subjected to wear and tear, and the following maintenance instructions must be acted upon when specified to ensure that the equipment remains within its original manufacturing specifications. Care and maintenance must be carried out in accordance with the preventive maintenance schedule below.

Customer obligations must be carried out by qualified personnel in accordance with the instructions in this manual.

**WARNING:** The maintenance described in the following checklist is the minimum that the manufacturer recommends. In some cases more frequent inspections should be carried out. Continuing to use this equipment without conducting regular inspections or when a fault is found will seriously compromise the safety of the user and of the patient.

**WARNING:** Safety related maintenance and authorized service must be carried out by qualified personnel, fully trained in servicing procedures by ArjoHuntleigh, and equipped with correct tools and proper documentation, including Parts List and Service Manual. Failure to meet these requirements could result in personal injuries and/or unsafe equipment.

## User Inspections

Inspections for lift cassette and rail system	FREQUENCY					
	Initially	Before every use	Every two months or 500 cycles	Every four months or 1000 cycles	Every year or 2500 cycles	Every two years or 5000 cycles
Inspect for evidence of external damage, missing parts or broken panels.	X	X				
Make sure that end stoppers and rail caps are in place and tightened.	X	X				
Inspect strap for wear, discoloration or loose threads.		X				
Recharge batteries.	X	X				
Inspect wheels in rail for damage, rust or cracks. Replace if damaged.					X	
Clean the rail and the clip-on charging station contacts.				X		
Make sure that all straps are attached to the spreader bar.		X				
Overall inspection by authorized personnel.					X	
Verify emergency stop cord.				X		
Verify emergency lowering device.				X		

# Care and Maintenance

Inspections for spreader bar and slings	FREQUENCY					
	Initially	Before every use	Every two months or 500 cycles	Every four months or 1000 cycles	Every year or 2500 cycles	Every two years or 5000 cycles
Inspect all sling parts (attachments, fabric, stitch areas and strap) for signs of wear, discoloration, deterioration or loose threads.		X				
Clean sling as indicated on the tag.	When necessary					
Inspect the spreader bar on the strap of the lift for damage or cracks. Make sure all attachments are properly secured (e.g. split ring).		X			X	

## Inspections by an Authorized Service Technician

Inspection for lift cassette	FREQUENCY					
	Initially	Before every use	Every two months or 500 cycles	Every four months or 1000 cycles	Every year or 2500 cycles	Every two years or 5000 cycles
Replace strap.						X
Inspect frame parts interlock and hardware for malfunction and make sure there are no parts missing.					X	
Inspect gears for wear and lubricate as necessary.					X	
Inspect connecting joints for proper attachment (trolley and spreader bar).					X	
Verify that the emergency brake on the drum is turning freely.					X	
Verify the emergency brake.					X	
Verify emergency lowering mechanism.					X	
Verify alternative up and down buttons on cassette.					X	
Load test with the SWL (safe working load) recommended.					X	
Verify the emergency stop for good functioning.					X	

# Care and Maintenance

Inspections for KWIKtrak* rails	FREQUENCY					
	Initially	Before every use	Every two months or 500 cycles	Every four months or 1000 cycles	Every year or 2500 cycles	Every two years or 5000 cycles
Torque end stoppers to 20 N. m. (15 lbf.ft).	X				X	
Make sure that the bracket locking device is not visible.	X				X	
Make sure rail joints are closed and that the spring pins are centered.	X				X	
Make sure the rail is straight when it is not loaded.	X				X	
Make sure the adjusted load setting of the lift is equal or lower than the safe working load of the installation.	X				X	
Check that the accessories (turntable and exchanger) are complete and correctly maintained.	X				X	
Make sure that the attachments (ceiling brackets, wall post, wall brackets) have not been displaced.	X				X	
Inspect rail end stoppers. Inspect and tighten hardware (if necessary).					X	
Load test with the SWL (safe working load) recommended.					X	

\*. For rail system other than KWIKtrak, refer to the manufacturer instructions of the rail system.

**NOTE: If the product does not work as intended, immediately contact your local ArjoHuntleigh agent.**

# Care and Maintenance

## Cleaning the Lift

**NOTE:** It is recommended to clean the lift and its accessories between each patient use.

### Removing visible residues:

- 1) Use a cloth soaked with water.
- 2) Remove visible residues from the lift and its accessories from top to bottom.

### Cleaning:

- 1) To clean the Voyager Duo and its accessories, spray cleaning fluid on the product, and use a brush (to remove any deposits).
- 2) Use a clean damp cloth with clear water to wipe off all spots of cleaning fluids.
- 3) If cleaning fluid cannot be removed on some hard-to-access parts, spray water on the affected part and wipe off with disposable towels/cloth. Repeat until all of the cleaning fluid has been removed.
- 4) Repeat steps 1 to 3 as necessary.
- 5) Let the parts dry.

**NOTE:** Pay special attention to areas pointed in Fig. 36. These are most likely to enclose germs. Use a smaller brush and/or cotton swab to reach them.

**CAUTION:** Do not drench the product, as this could damage electrical components and cause internal corrosion.

If a hot air dryer is used to dry the lift, the temperature must not exceed 80°C (176 °F).

Do not use petroleum-based solvents, as this may damage plastic parts.

To ensure a better rolling surface for the trolley wheels, clean the inside of the rail every 4 months. To do so, insert a damp cloth in the opening and slide it from one end of the rail to the other.

### Voyager Duo's Special Areas to Clean

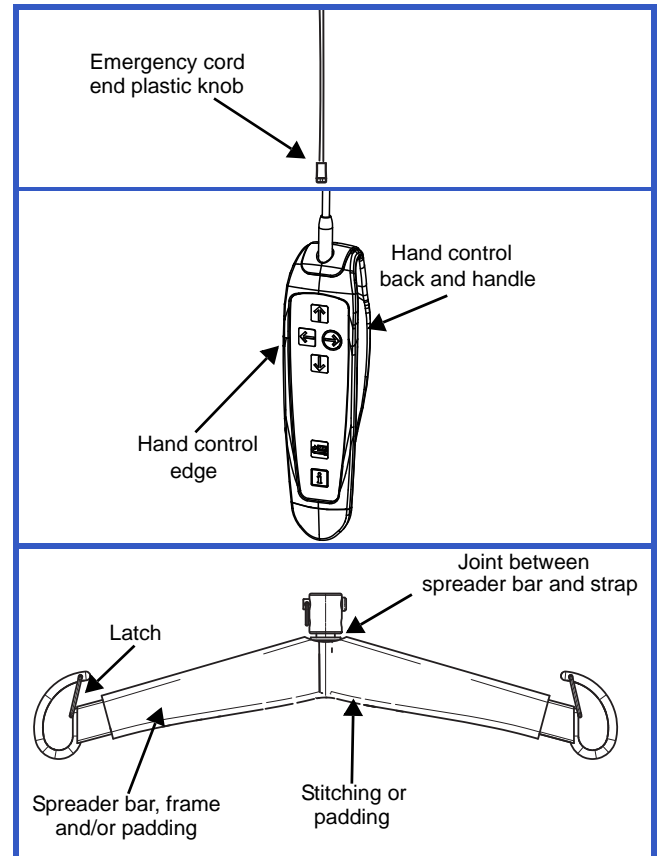

Fig. 36

**WARNING:** To avoid eye and skin injuries, cleaning and disinfection products must be used in accordance with the instructions. Wear the appropriate eye, hand and clothing protection at all times when handling disinfectants.

# Care and Maintenance

## Strap Inspection

If the strap is damaged or shows signs of wear or discoloration, the acceptable load on the strap before rupture can drop rapidly and present a danger for the patient or caregiver. ArjoHuntleigh recommends a quick inspection of the straps before every use and a thorough inspection every 2 months as follows:

- 1) Completely unwind the strap.
- 2) Look for any signs of wear or discoloration (see Fig. 37).

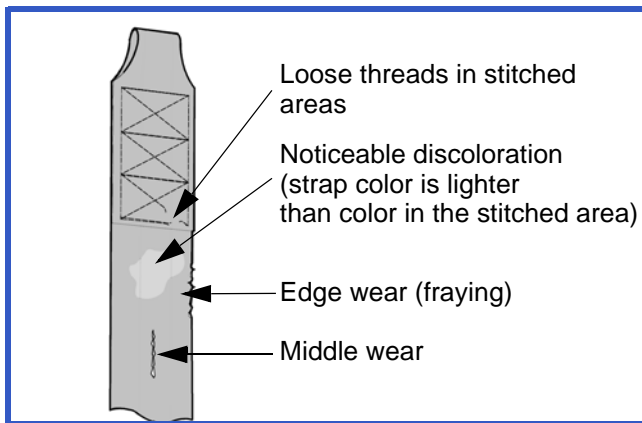

Fig. 37

**WARNING:** If there is any sign of wear as indicated above or any other visual defects, the strap must be changed. By continuing to use the lift without changing a damaged strap, the safety of the caregiver or patient is greatly compromised.

**NOTE:** The manufacturer recommends changing the strap at least every two years.

## Handling and Storage

Avoid violent impacts while transporting the lift.

The lift should not remain stored for long periods of time without recharging the batteries.

**NOTE:** Even if the lift is not used, ArjoHuntleigh recommends charging the batteries at least every two weeks. This will prevent premature aging of batteries.

If you store or ship the Voyager Duo, ensure that the power is turned off (green light) beforehand.

## Batteries Replacement

Replace the batteries when there is a noticeable reduction in the number of transfers that can be performed between charges.

To replace batteries, contact your local ArjoHuntleigh agent.

## Sling Inspection and Care

See the documentation included with the sling.

## Annual Inspection

**WARNING:** The Voyager Duo lift and accessories must be serviced by a qualified technician every 12 months as a minimum requirement. This inspection is mandatory to ensure the safe use of the device for the patient and caregiver.

# Troubleshooting

**WARNING: Do not attempt to open the Voyager Duo ceiling lift cassette. Only a qualified technician is authorized to open it. Alterations made to the Voyager Duo ceiling lift cassette by someone other than a qualified technician may cause serious injury.**

PROBLEM	TO CHECK
The red “service” light is on and flashing.	<ul style="list-style-type: none"> <li>Contact your local ArjoHuntleigh agent to do maintenance.</li> </ul>
The red light is solid.	<ul style="list-style-type: none"> <li>The ceiling lift cassette is under its overheat protection. Wait between 10 to 30 minutes until the red light turns off and press on the “UP” button to use the ceiling lift cassette again.</li> </ul>
The light does not illuminate when there are batteries correctly installed	<ul style="list-style-type: none"> <li>Make sure that the charger is correctly plugged into the AC outlet, and that the green light on the clip-on charging station is on.</li> <li>Make sure that there is contact between the contact blades of the lift and the contact plates of the charging station.</li> <li>Check the power of the AC outlet on the wall.</li> <li>If the charge station’s green light does not light up, contact your local ArjoHuntleigh agent.</li> </ul>
The unit starts and stops repetitively.	<ul style="list-style-type: none"> <li>If the load is over a safe working load, the unit will not work due to the overload protection on the motor.</li> </ul>
The ceiling lift cassette emits a beep during utilization. The unit may stop lifting but the lowering function can still be used.	<ul style="list-style-type: none"> <li>Batteries are low. Return the ceiling lift cassette to the charging station.</li> </ul>
The charger indicator (yellow) on the ceiling lift cassette does not light up when the lift is on the charger.	<ul style="list-style-type: none"> <li>Check that the charger is plugged into a standard outlet, and that the outlet has power. The green light on the clip-on charging station indicates that it is functioning.</li> </ul>
When returning to charge, the ceiling lift cassette passes the clip on the charging station, or goes in the wrong direction.	<ul style="list-style-type: none"> <li>Clean the contact blades of the charging station with mild detergent. Pass the ceiling lift cassette through the charging station manually once, then retry the return to charger function.</li> </ul>
Batteries are always dead after only a few transfers (3 to 5).	<ul style="list-style-type: none"> <li>Verify the function of the ceiling lift charger and the contact plates on the clip-on charging station.</li> <li>Contact your local ArjoHuntleigh agent to have the batteries replaced.</li> </ul>
The yellow light on the unit is solid, yet the ceiling lift cassette will only perform one or two transfers.	<ul style="list-style-type: none"> <li>Contact your local ArjoHuntleigh agent to have batteries replaced.</li> </ul>
The yellow light on the unit is solid, yet the ceiling lift will only work when there is no one on the lift. When you try to transfer someone, the ceiling lift stops.	<ul style="list-style-type: none"> <li>Contact your local ArjoHuntleigh agent to have the batteries replaced.</li> </ul>

# Troubleshooting

PROBLEM	TO CHECK
<p>The ceiling lift does not work when you press the buttons on the hand control.</p>	<ul style="list-style-type: none"> <li>• If the charging station light is on, move the ceiling lift away from the charging station in order to operate the lift.</li> <li>• If the emergency stop is activated, gently push up on the reset switch plastic insert to turn the unit back on.</li> <li>• Check if the buttons on the ceiling lift cassette are working. If so, the problem may be coming from the hand control. If not, check the charge on the ceiling lift.</li> <li>• Slide the ceiling lift over the clip-on charging station. Verify if the yellow light turns on.</li> <li>• If, after testing all of the above, the ceiling lift will not operate, contact your local ArjoHuntleigh agent.</li> </ul>
<p>The charging light on the ceiling lift cassette continues flashing yellow and the light does not turn solid even after recharging the unit overnight.</p>	<ul style="list-style-type: none"> <li>• If available, try another integrated clip-on charging station from another ceiling lift, or a spare one; clip it to the rail and charge the unit for 3 hours. If the yellow light is still flashing, contact your local ArjoHuntleigh agent.</li> </ul>
<p>When you press the button to return the ceiling lift to its charger (4-way motor only), the ceiling lift goes past the charger.</p>	<ul style="list-style-type: none"> <li>• The charger either plugged in properly to an electrical outlet or is not working properly. Contact your local ArjoHuntleigh agent.</li> </ul>



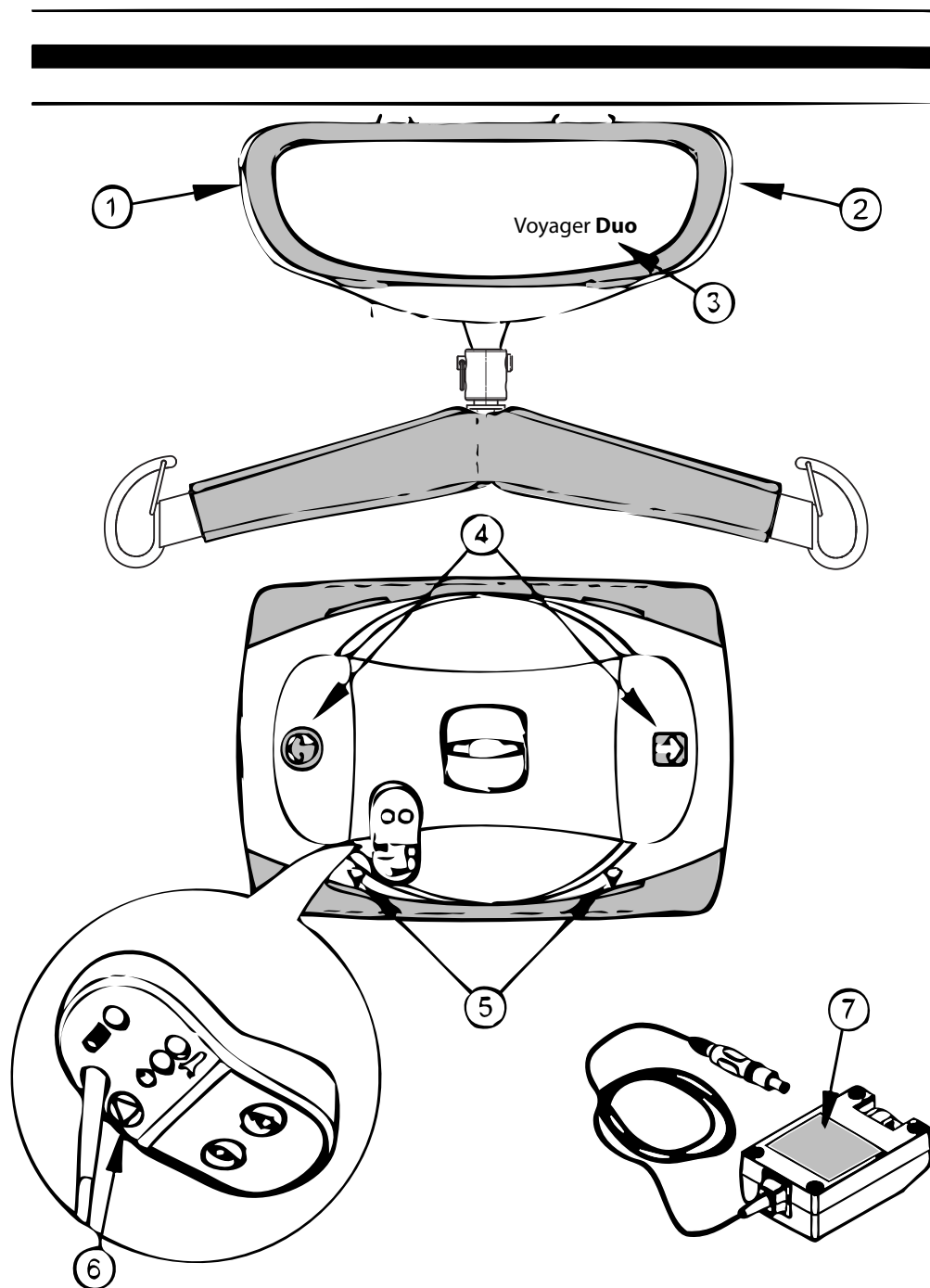

- 1) Maximum capacity/Service telephone number
- 2) Date of manufacture, serial number, product code and Manufacturer identification
- 3) Product name
- 4) Travel direction indicators
- 5) Emergency lowering system access identification
- 6) Emergency stop identification
- 7) Charger information

Fig. 38

# Technical Specifications

PRODUCT INFORMATION		Voyager Duo
Weight, complete (four-function model)	12.7 kg (28 lb)	
Weight, complete (two-function model)	11.4 kg (25 lb)	
Weight of spreader bar	2.5 kg	
Lifting capacity	100 kg (220 lb) or 200 kg (440 lb)	
Strap length	2300 mm (90.6 in)	
Lifting speed	6.0 cm/s (2.4 in/s) (without load) 3.5 cm/s (1.4 in/s) at 200 kg (440 lb)	
Maximum stroke (from ceiling)	2300 mm (90.6 in)	
Horizontal displacement speeds	10, 15, 20 and 25 cm/s. Speed is 20 cm/s (7.9 in/s) by default	
Horizontal axis motor	24 VDC, 62 watts	
Vertical axis motor	24 VDC, 110 watts	
Operating force of control	< 5 N	
ELECTRICAL		
Duty cycle	Max 10%, 1 minute continuously	
Rating	24 VDC, 15 A max.	
Noise level for either raising or lowering, with or without load	61 dBA max.	
Medical equipment	Type BF protection against electrical shock in accordance with IEC 60601-1	
The Voyager Duo ceiling lift is compliant with CAN/CSA C22.2 No. 601.1 (SUP1+AM2), UL 60601 1, CAN/CSA-C22.2 No. 60601-1-08, ANSI/AAMI ES60601-1:2005, and designed according to ISO 10535:2006.		
<b>WARNING: Wireless communications equipment such as wireless home network devices, mobile phones, cordless telephones and their base stations, walkie-talkies, etc. can affect the Voyager Duo unit and should be kept at least 2.3 m away from it. Cables from potentially strong sources of electromagnetic fields should not be placed near the unit.</b>		
Battery type	Sealed rechargeable valve regulated lead acid batteries. Rating: 24V, 5Ah (2x 12V series connected)	
Battery capacity	Provides up to 120 transfers with a load of 100 kg (220 lb), up to 70 transfers with a load of 200 kg (440 lb)	
Degree of protection - Hand Control	IPX7	
Degree of protection - Voyager Duo	IP21	
Lift - protection class - shock prevention	Internally powered equipment	
Battery Charger input	100-240 VAC 50-60 Hz, 57-70 VA or 100-240 VAC, 50-60Hz, 50 VA	
Battery Charger output	28.1 VDC, 1 A, 28.1 VA or 24VDC, 1A, 24 VA	
Battery Charger safety protection	Class 2, double insulated	
OPERATION AND STORAGE CONDITIONS		
Ambient temperature range	<b>Operation:</b> 5 to 40 °C (+41 °F to +104 °F) <b>Storage:</b> -25 to +70°C (-13 °F to +158 °F)	
Relative humidity range	<b>Operation:</b> 15 % to 93 %, non-condensing <b>Storage:</b> Up to 93 %, non-condensing	
Atmospheric pressure range	<b>Operation:</b> 700 hPa to 1060 hPa (2000 m max) <b>Storage:</b> 500 hPa to 1060 hPa	
<b>WARNING: This product is not suitable in the presence of flammable anesthetic mixtures with air or oxygen, or with nitrous oxide. Using the Voyager Duo in this environment might lead to an explosion. The lift might create some spark internally and ignite the gaz.</b>		
RECYCLING		
Battery	Sealed lead-acid, rechargeable, recyclable	
Package	Cardboard recyclable	
The lift	Separated and recycled, according to the European Directive 2002/96/EG (WEEE).	

# Technical Specifications

## Lift Dimensions

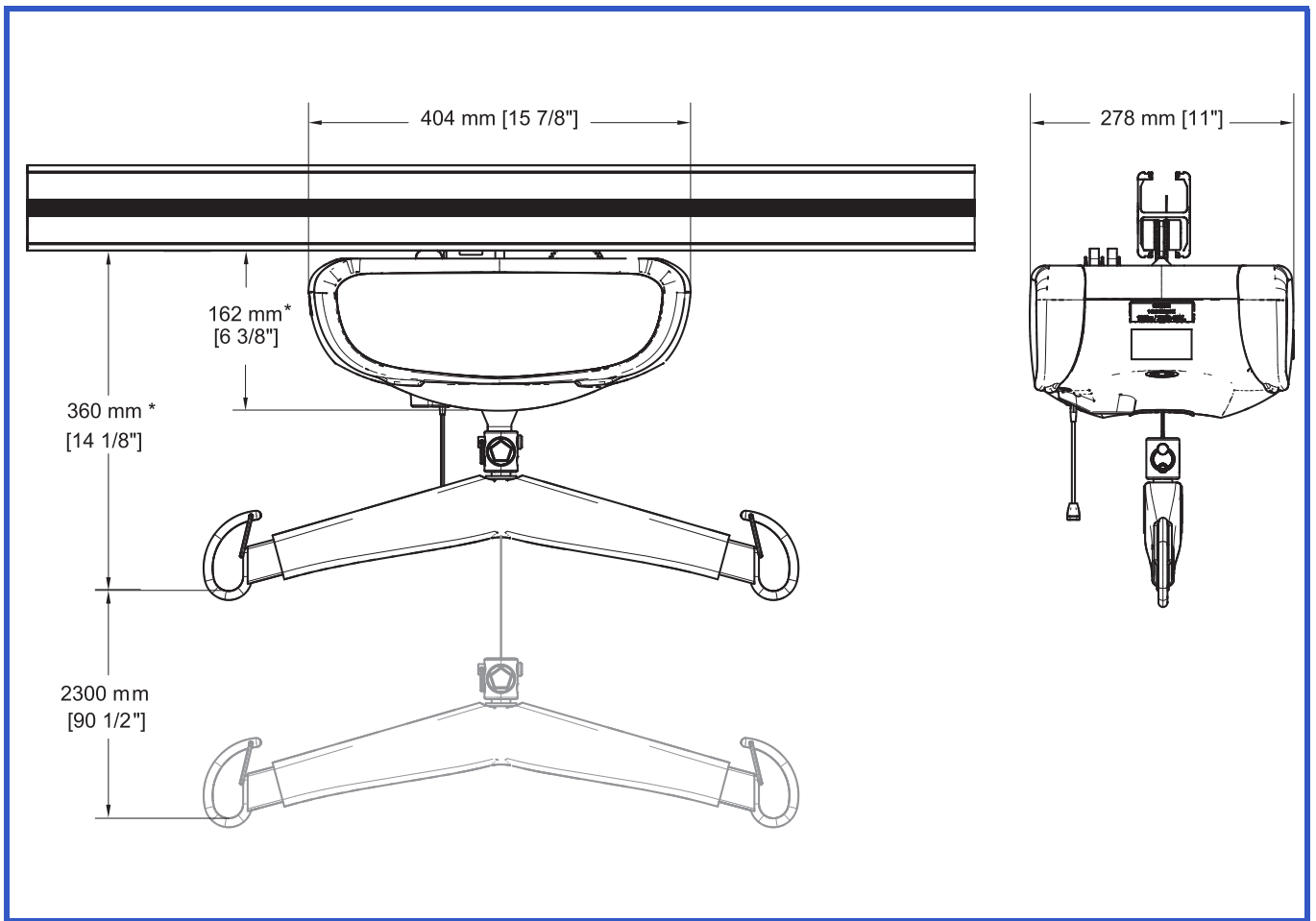

Fig. 39

\* Refer to the addendum for rail system other than KWIKtrak.

# Electromagnetic Compatibility

## Electromagnetic Compliance

The Voyager Duo has been tested for compliance with current regulatory standards regarding its capacity to block EMI (electromagnetic interference) from external sources.

Nonetheless, some procedures can help reduce electromagnetic interferences:

- Use only ArjoHuntleigh cables and spare parts to avoid increased emissions or decreased immunity which can compromise the correct functioning of the equipment.
- Ensure that other devices in patient-monitoring and/or life-support areas comply to accepted emissions standards.
- Maximize the distance between electro-medical devices. High-powered devices may produce EMI that can affect the ceiling lift. Refer to separation distance table further on in this document.

For more information on how to manage the unit's RF electromagnetic environment, please consult the *AMI TIR 18-1997 - Guidance on Electromagnetic Compatibility of Medical Devices for Clinical/Biomedical Engineers*.

## Electromagnetic Emissions

### Guidance and Manufacturer's Declaration - Electromagnetic Emissions - For all Equipment and Systems

The Voyager Duo is intended for use in the electromagnetic environment indicated below. The customer or the user of the Voyager Duo should assure that it is used in such an environment.

Emissions test	Compliance	Electromagnetic environment - guidance
RF emissions CISPR 11	Group 1	The Voyager Duo uses RF energy only for its internal function. Therefore, its RF emissions are very low and are not likely to cause any interference in nearby electronic equipment.
RF emissions ISPR 11	Class B	
Harmonic emissions	Not applicable	The Voyager Duo is suitable for use in all establishments, including domestic establishments and those directly connected to the public low-voltage power supply network that supplies buildings used for domestic purposes.
Voltage fluctuations/flicker emissions IEC 61000-3-3	Not applicable	

# Electromagnetic Compatibility

## Electromagnetic Immunity

### Guidance and Manufacturer's Declaration - Electromagnetic Immunity - For all Equipment and Systems

The Voyager Duo is intended for use in electromagnetic environment specified below. The customer or the user of the Voyager Duo should assure that it is used in such an environment.

Immunity test	IEC 60601 test level	Compliance level	Electromagnetic environment - guidance
Electrostatic discharge (ESD)  IEC 61000-4-2	±6 kV contact ±8 kV air	±6 kV contact ±8 kV air	Floors should be wood, concrete or ceramic tile. If floors are covered with synthetic material, the relative humidity should be at least 30%.
Electrical fast transient/burst  IEC 61000-4-5	±2 kV for power supply lines ±1 kV for input/output lines	±2 kV for power supply lines Not applicable for input/output lines	Mains power quality should be that of a typical commercial or hospital environment.
Surge  IEC 61000-4-5	±1 kV differential mode ±2 kV for input/output	Not applicable	
Voltage dips, short interruptions and voltage variations on power supply input lines  IEC 61000-4-11	<5% <i>UT</i> (>95% dip in <i>UT</i> ) for 0.5 cycle  40% <i>UT</i> (60% dip in <i>UT</i> ) for 5 cycles  70% <i>UT</i> (30% dip in <i>UT</i> ) for 25 cycles  <5% <i>UT</i> (>95% dip in <i>UT</i> ) for 5 sec.	Not applicable	
Power frequency (50/60 Hz) magnetic field	3 A/m	3 A/m	Power frequency magnetic fields should be at levels characteristic of a typical location in a typical commercial or hospital environment.

NOTE: *UT* is the AC mains voltage prior to application of the test level.

# Electromagnetic Compatibility

(continued)

Guidance and Manufacturer's Declaration - Electromagnetic Immunity - For Equipment and Systems that are Not Life-Supporting			
Immunity test	IEC 60601 test level	Compliance level	Electromagnetic environment - guidance
Conducted RF IEC 61000-4-6	3 Vrms 150 kHz to 80 Mhz	3 Vrms 150 kHz to 80 Mhz	<p>Portable and mobile RF communications equipment should be used no closer to any part of the Voyager Duo, including cables, than the recommended separation distance calculated from the equation applicable to the frequency of the transmitter.</p> <p>Recommended separation distance</p> $d = \left[ \frac{3.5}{V1} \right] \sqrt{P}$ $d = \left[ \frac{3.5}{E1} \right] \sqrt{P} \quad 80 \text{ MHz to } 800 \text{ MHz}$ $d = \left[ \frac{7}{E1} \right] \sqrt{P} \quad 800 \text{ MHz to } 2.5 \text{ GHz}$
Radiated RF IEC 61000-4-3	3 V/m 80 MHz to 2.5 GHz	3 V/m 80 MHz to 2.5 GHz	<p>where <math>P</math> is the maximum output power rating of the transmitter in watts (W) according to the transmitter manufacturer and <math>d</math> is the recommended separation distance in meters.</p> <p>Field strengths from fixed RF transmitters, as determined by an electromagnetic site survey, <sup>(a)</sup> should be less than the compliance level in each frequency range. <sup>(b)</sup></p> <p>Interference may occur in the vicinity of equipment marked with the following symbol:</p> 
NOTE 1: At 80 MHz and 800 MHz, the higher frequency range applies.			
NOTE 2: These guidelines may not apply in all situations. Electromagnetic propagation is affected by absorption and reflection from structures, objects and people.			
(a) Field strengths from fixed transmitters, such as base stations for radio (cellular/cordless) telephones and land mobile radios, amateur radio, AM and FM radio broadcast and TV broadcast cannot be predicted theoretically with accuracy. To assess the electromagnetic environment due to fixed RF transmitters, an electromagnetic site survey should be considered. If the measured field strength in the location in which the Voyager Duo is used exceeds the applicable RF compliance level above, the Voyager Duo should be observed to verify normal operation. If abnormal performance is observed, additional measures may be necessary, such as reorienting or relocating the Voyager Duo.			
(b) Over the frequency range 150 kHz to 80 MHz, field strengths should be less than 3 V/m.			

# Electromagnetic Compatibility

(continued)

## Recommended Separation Distance Between - Portable and Mobile RF Communications Equipment and the Voyager Duo for Equipment and Systems that are not Life-Supporting

Recommended separation distances between portable and mobile RF communications equipment and the Voyager Duo.

The Voyager Duo is intended for use in electromagnetic environment in which radiated RF disturbances are controlled. The customer or the user of the Voyager Duo can help prevent electromagnetic interference by maintaining a minimum distance between portable and mobile RF communication equipment (transmitters) and the Voyager Duo as recommended below, according to the maximum output power of the communications equipment.

Rated maximum output power of transmitter <b>W</b>	Separation distances according to frequency of transmitter <b>m</b>		
	150 kHz to 80 MHz	80 MHz to 800 MHz	800 MHz to 2.5 GHz
	$d = \left[ \frac{3.5}{V1} \right] \sqrt{P}$	$d = \left[ \frac{3.5}{E1} \right] \sqrt{P}$	$d = \left[ \frac{7}{E1} \right] \sqrt{P}$
0.01	0.12	0.12	0.24
0.1	0.38	0.38	0.74
1	1.2	1.2	2.4
10	3.8	3.8	7.4
100	12	12	24

For transmitters rated at a maximum output power not listed above, the recommended separation distance  $d$  in metres (m) can be estimated using the equation applicable to the frequency of the transmitter, where  $P$  is the maximum output power rating of the transmitter in watts (W) according to the transmitter manufacturer.

NOTE 1: At 80 MHz and 800 MHz, the separation distance for the higher frequency range applies.

NOTE 2: These guidelines may not apply in all situations. Electromagnetic propagation is affected by absorption and reflection from structures, objects and people.









**AUSTRALIA**

ArjoHuntleigh Pty Ltd  
78, Forsyth street  
O'Connor  
AU-6163 Western Australia  
Tel: +61 89337 4111  
Free: +1 800 072 040  
Fax: + 61 89337 9077

**BELGIQUE / BELGIË**

ArjoHuntleigh NV/SA  
Evenbroekveld 16  
B-9420 ERPE-MERE  
Tél/Tel: +32 (0) 53 60 73 80  
Fax: +32 (0) 53 60 73 81  
E-mail: info@arjohuntleigh.be

**CANADA**

ArjoHuntleigh  
90 Matheson Boulevard West  
Suite 300  
MISSISSAUGA, ON, L5R 3R3  
Tel/Tél: +1 905 238 7880  
Free: +1 800 665 4831 Institutional  
Free: +1 800 868 0441 Home Care  
Fax: +1 905 238 7881  
E-mail: info.canada@arjohuntleigh.com

**ČESKÁ REPUBLIKA**

ArjoHuntleigh s.r.o.  
Hlinky 118  
CZ- 603 00 BRNO  
Tel: +420 549 254 252  
Fax: +420 541 213 550

**DANMARK**

ArjoHuntleigh A/S  
Vassingerødvej 52  
DK-3540 LYNGE  
Tel: +45 49 13 84 86  
Fax: +45 49 13 84 87  
E-mail: info.dk@arjohuntleigh.com

**DEUTSCHLAND**

ArjoHuntleigh GmbH  
Peter-Sander-Strasse 10  
D-55252 MAINZ-KASTEL  
Tel: +49 (0) 6134 186 0  
Fax: +49 (0) 6134 186 160  
E-mail: info-de@arjohuntleigh.com

**ΕΛΛΑΔΑ**

C. Psimitis Co Ltd  
Dimitriou Andr. 59  
GR-16121 KAISARIANI ATTIKIS  
Τηλ: 21 0724 36 68  
Φάξ: 21 0721 55 53

**ESPAÑA**

ArjoHuntleigh Ibérica S.L.  
Ctra. de Rubí, 88 1ª planta - A1  
08173 Sant Cugat del Vallés  
ES- BARCELONA 08173  
Tel: +34 93 583 11 20  
Fax: +34 93 583 11 22  
E-mail: info.es@arjohuntleigh.com

**FAR EAST**

ARJO Far East Limited  
Unit 3A, 4/F., block B Hoi Luen  
Industrial Centre  
55 Hoi Yuen Road,  
Kwun Tong, Kowloon  
HONG KONG  
Tel: +852 2508 9553  
Fax: +852 2508 1416

**FRANCE**

ArjoHuntleigh SAS  
2 Avenue Alcide de Gasperi  
CS 70133  
59436 RONCQ CEDEX  
Tél: +33 (0) 3 20 28 13 13  
Fax: +33 (0) 3 20 28 13 14  
E-mail : info.france@arjohuntleigh.com

**INTERNATIONAL**

ArjoHuntleigh International Ltd.  
ArjoHuntleigh House  
Houghton Hall Park  
Houghton Regis  
UK-DUNSTABLE LU5 5XF  
Tel: +44 (0) 1582 745 800  
Fax: +44 (0) 1582 745 866  
E-mail:  
international@ArjoHuntleigh.com

**ITALIA**

ArjoHuntleigh S.p.A.  
Via di Tor Vergata 432  
00133 ROMA - ITALIA  
Tel: +39 (0) 6 87426211  
Fax: +39 (0) 6 87426222  
E-mail: Italy.promo@arjohuntleigh.com

**NEDERLAND**

ArjoHuntleigh Nederland BV  
Biezenwei 21  
4004 MB TIEL  
Postbus 6116  
4000 HC TIEL  
Tel: +31 (0) 344 64 08 00  
Fax: +31 (0) 344 64 08 85  
E-mail: info.nl@arjohuntleigh.com

**NEW ZEALAND**

ArjoHuntleigh Ltd  
41 Vestey Drive  
Mount Wellington  
AUCKLAND 1060  
Tel: +64 (0) 9 573 5344  
Free Call: 0800 000 151  
Fax: +64 (0) 9 573 5384  
E-mail: nz.info@ArjoHuntleigh.com

**NORGE**

ArjoHuntleigh Norway AS  
Ryenstubben 2  
NO-0679 OSLO  
Tel: +47 22 08 00 50  
Faks: +47 22 08 00 51  
E-mail: no.kundeservice@arjohuntleigh.com

**POLSKA**

ArjoHuntleigh Polska Sp. z o.o.  
ul. Ks Piotra Wawrzyniaka 2  
PL 62-052 KOMORNIKI (Poznan)  
Tel: +48 61 662 15 50  
Fax: +48 61 662 15 90  
E-mail: arjo@arjohuntleigh.com

**PORTUGAL**

ArjoHuntleigh em Portugal:  
MAQUET Portugal, Lda. (Distribuidor Exclusivo)  
Rua Poeta Bocage n.º 2 - 2G  
1600-233 Lisboa, Portugal  
Tel: +351 214 189 815  
Fax: +351 214 177 413  
E-mail: Portugal@arjohuntleigh.com

**SUISSE / SCHWEIZ**

ArjoHuntleigh AG  
Fabrikstrasse 8  
Postfach  
4614 Hägendorf,  
Tél/Tel: +41 (0) 61 337 97 77  
Fax: +41 (0) 61 311 97 42

**SUOMI**

ArjoHuntleigh OY  
Vanha Porvoontie 229  
FI-01380 VANTAA  
Puh: +358 9 4730 4320  
Faksi: +358 9 4730 4999

**SVERIGE**

ARJO Scandinavia AB  
Verkstadsvägen 5  
Box 61  
SE-241 21 ESLÖV  
Tel: +46 (0) 10-335 45 00  
Fax: +46 (0) 413-138 76  
E-mail: kundservice@arjohuntleigh.com

**UNITED KINGDOM**

ArjoHuntleigh UK  
ArjoHuntleigh House  
Houghton Hall Park  
Houghton Regis  
UK-DUNSTABLE LU5 5XF  
Tel: +44 (0) 1582 745 700  
Fax: +44 (0) 1582 745 745  
E-mail:  
sales.admin@ArjoHuntleigh.com

**USA**

ArjoHuntleigh Inc.  
2349 W Lake Street Suite 250  
Addison, IL 60101  
Tel: +1 630 307 2756  
Free: +1 800 323 1245 Institutional  
Free: +1 800 868 0441 Home Care  
Fax: +1 630 307 6195  
E-mail: us.info@ArjoHuntleigh.com

**ÖSTERREICH**

ArjoHuntleigh GmbH  
Dörrstrasse 85  
AT-6020 INNSBRUCK  
Tel: +43 (0) 512 204 160 0  
Fax: +43 (0) 512 204 160 75

# ARJOHUNBLEIGH

GETINGE GROUP

**GETINGE GROUP** is a leading global provider of products and systems that contribute to quality enhancement and cost efficiency within healthcare and life sciences. We operate under the three brands of **ArjoHuntleigh**, **GETINGE** and **MAQUET**. **ArjoHuntleigh** focuses on patient mobility and wound management solutions. **GETINGE** provides solutions for infection control within healthcare and contamination prevention within life sciences. **MAQUET** specializes in solutions, therapies and products for surgical interventions and intensive care.

[www.ArjoHuntleigh.com](http://www.ArjoHuntleigh.com)



**ArjoHuntleigh AB**  
Verkstadsvägen 5  
241 38 Eslöv  
SWEDEN

