

Voyager
Instructions for Use

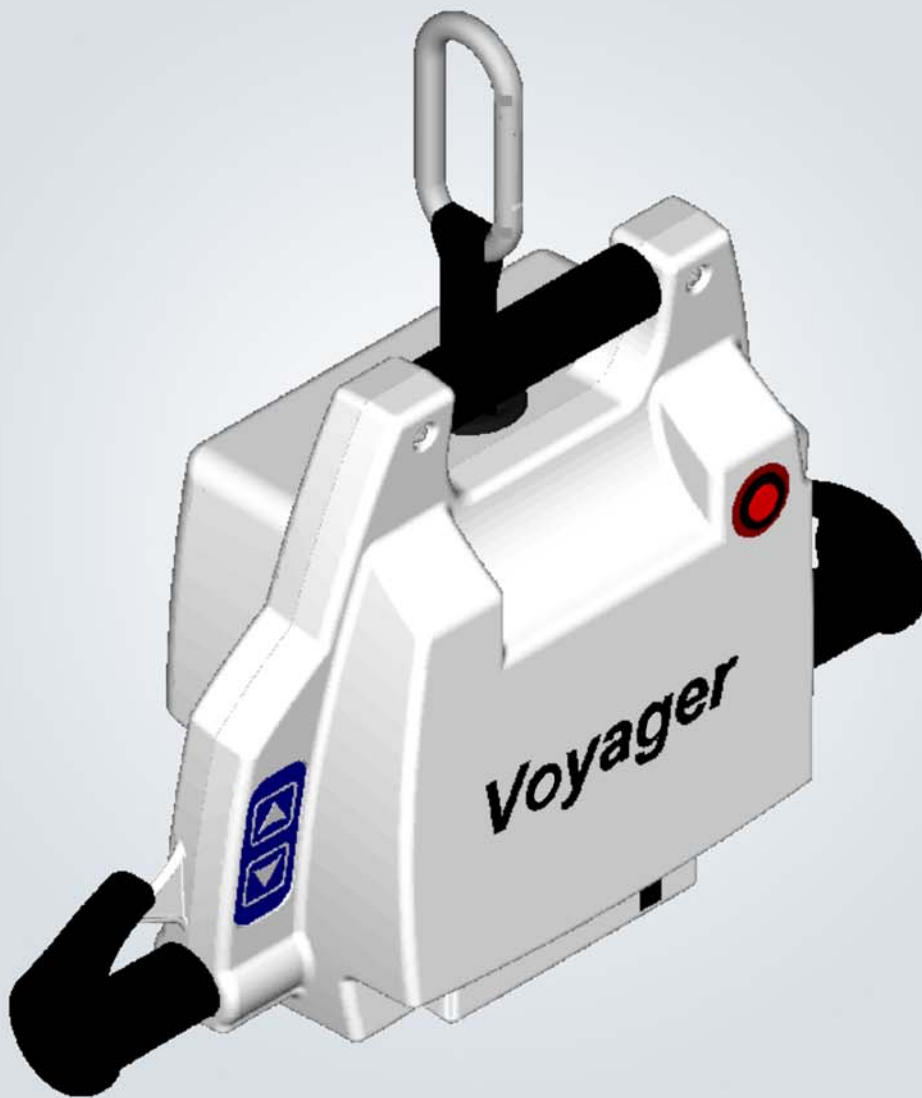

Design Policy and Copyright

® and ™ are trademarks belonging to the ArjoHuntleigh group of companies.

© ArjoHuntleigh 2011.

As our policy is one of continuous improvement, we reserve the right to modify designs without prior notice.

The content of this publication may not be copied either whole or in part without the consent of ArjoHuntleigh.

Table of Contents

General Information	4
Foreword	4
Service and Support	4
Manufacturer Information.....	4
Definitions Used in this Manual	5
Intended Use	5
Operational Life	5
Product Identification	5
Package Contents	5
How to Use this Manual	5
Symbols Used.....	6
Safety Instructions	7
General Instructions	7
Safe Working Load	7
Important Safety Directions	7
Shock Prevention.....	8
Fire and Explosion Prevention.....	8
Human and Environmental Safety Practices	8
Environmental Advice	8
Battery and Battery Charger Safety Practices	8
Homecare Environment Considerations	8
Parts Designation	9
Voyager Portable Lift and Charging Station	9
Hand Control	10
Accessories	11
Slings	12
Compatible Slings	12
How to Use the Voyager	13
Use of Slings	13
Before Approaching the Patient.....	13
Transferring the Patient	14
Emergency Lowering	15
Emergency Brake	15
Battery Information	16
Charging the Battery	16
Care and Maintenance	17
Preventive Maintenance Schedule	17
User Inspections.....	17
Inspections by an Authorized Service Technician	18
Cleaning the Lift.....	19
Strap Inspection.....	20
Handling and Storage.....	20
Battery Replacement	20
Sling Inspection and Care	20
Annual Inspection	20
Troubleshooting	21
Labels on the Lift	23
Technical Specifications	24
Lift Dimensions	25
Electromagnetic Compatibility	26
Electromagnetic Compliance.....	26
Electromagnetic Emissions.....	26
Electromagnetic Immunity	27

General Information

Thank you for buying the Voyager® portable lift from ArjoHuntleigh.

Your Voyager is part of a series of quality products designed specially for home care, nursing homes and other health care uses.

We are dedicated to serving your needs and providing the best products available along with training that will bring your staff maximum benefit from every ArjoHuntleigh product.

Contact us if you have any questions about the use or maintenance of your ArjoHuntleigh product.

Foreword

Please read this manual in its entirety. The information contained in it is crucial to the proper use and maintenance of the Voyager. It will help protect your product as well as ensure that it performs to your satisfaction.

Lifting and transferring a person always present a potential risk. Some of the information in this manual is important for your safety and must be read and understood to help prevent injuries.

WARNING: Injuries can be attributed to the use of inadequate parts. Use only parts designated by ArjoHuntleigh with you Voyager.

WARNING: Unauthorized changes on any ArjoHuntleigh product may affect its safety. ArjoHuntleigh will not be held responsible for any accidents, incidents or deficiencies of performance that occur as a result of any unauthorized changes to its products.

Tested according to standards by: 

Service and Support

A service routine must be done on your Voyager by ArjoHuntleigh trained service staff. This will ensure the product remains safe and functional. See “Care and Maintenance” section.

Please contact your local ArjoHuntleigh agent if you need more information, want to report an unexpected event or lack of performance, or if you need any help in setting up, using or maintaining your Voyager. The agent can offer support and service programs to maximize the long-term safety, reliability and value of the product.

Contact your local agent for replacement parts.

Additional copies of this manual can be bought from your local ArjoHuntleigh agent. When ordering, include the *Instructions for Use* part number (see *front page*) and the product part number.

Manufacturer Information

This product has been manufactured by:

ArjoHuntleigh AB
Verkstadsvägen 5
241 38 Eslöv
SWEDEN
☎: +46 (0) 10-335 45 00
📠: +46 (0) 413-138 76
🌐: www.ArjoHuntleigh.com

Definitions Used in this Manual

WARNING:

Means: Failure to understand and follow these instructions may result in injury to yourself and others.

CAUTION:

Means: Failure to follow these instructions may cause damage to the product.

NOTE:

Means: This is important information regarding the correct use of the equipment.

Intended Use

The Voyager is designed for lifting patients in a homecare setting, at nursing homes and other assisted living centers. Patient transfers must be done under the supervision of trained caregivers in accordance with the instructions found in this manual.

The product must only be used for the purposes stated above. It must be installed by ArjoHuntleigh authorized personnel and in accordance with local codes.

Operational Life

The product is designed and tested for a useful life of seven (7) years or 10,000 transfers, whichever comes first. It is subject to preventive maintenance as specified in the "Care and Maintenance" section.

Time equivalence between the number of transfers versus the number of years is made clear in the table in Fig. 1.

TRANSFERS PER DAY	YEARS (10,000 TRANSFERS)
4	7
6	4.5
8	3.5

Fig. 1

WARNING: The manufacturer cannot ensure full safety for a portable lift or an accessory of which the life span has been exceeded. Wear may cause the breakage of a part and lead to a patient fall.

The operating life of this product corresponds directly to the safe operating time period before a complete service is required.

Aging of the cassette, frequency of use (transfers per day), the weight of the patient and maintenance frequency are factors that have an impact on the Voyager's life span.

A transfer is defined as the displacement of a patient from one point to another. A transfer cycle includes a lifting and a descending action.

The expected operational life for fabric slings and stretchers is approximately two years from purchase date. The life expectancy only applies if the slings and stretchers have been cleaned, maintained and inspected in accordance with the "Preventive Maintenance Schedule."

The expected life for other consumable products, such as batteries, fuses, lamps, slings, straps and cords is dependent upon the care and usage of the product concerned. Consumables must be maintained in accordance with published *Instructions for Use* and the "Preventive Maintenance Schedule".

Product Identification

The lift's identification number (specification, model, serial number) appears on a silver nameplate affixed on the back of the casing.

Package Contents

Upon receipt of the equipment, verify it against the packing list to ensure it is complete. Inspect it for possible damage due to shipping. If this the case, contact your local ArjoHuntleigh agent.









How to Use this Manual





WARNING: Do not attempt to use this lift without fully understanding the information contained in this manual. A misuse of this unit may lead to a patient fall and to injuries.

Keep this manual with the lift and refer to it as required.

General Information

Symbols Used

General Symbols	Key to symbols
	Points out the date of manufacture and the address of the manufacturer.
	Points out the products comply with the medical device directive 93/42/EEC.
	Points out the approval of the Canadian Standards Association.
	Is accompanied by the manufacturer's catalogue number.
	Is accompanied by the manufacturer's serial number.
	Refers to the <i>Instructions for Use</i> .
	Points out "separate collection" for all batteries and accumulators as per the WEEE Directive.
	Points out a risk of pinching.

General Symbols	Key to symbols
	Points out the product must be kept dry.
SWL	Represents the maximum load the lifter is rated for safe operation.
IP_{N₁}N₂	Degree of protection provided by enclosure. N ₁ : Ingress of particles, N ₂ : Ingress of water.
	Direct current.
	Alternating current.
	Points out a type BF applied part.

Charger Related Symbol	Key to symbol
	Points out a class II electrical equipment: term referring to electrical equipment in which protection against electric shock does not rely on basic insulation only.

Safety Instructions

General Instructions

WARNING: The Voyager lift is for transferring patients only. Do not use the lift for any other purpose. Failure to do so may result in injuries to you or to others.

CAUTION: Do not drop the ceiling lift. This could cause internal damage that is not easily seen. If the ceiling lift is suspected to be damaged, contact your local ArjoHuntleigh agent.

WARNING: Always place the sling around the patient according to the instructions found therein. Failure to do so may result in injuries to you or to others.

NOTE: ArjoHuntleigh portable lifts are specifically designed for *KWIKtrak* rail system and ArjoHuntleigh slings and accessories.

Addendum for Rail Systems other than *KWIKtrak*TM

ArjoHuntleigh offers a series of adapted accessories. This lift could also be used with a rail system other than *KWIKtrak*. If this is the case, an addendum is supplied with the adapted accessory. This document provides important information relative to:

- Rail system limitations;
- Descriptions of specific parts.

WARNING: Before using the Voyager with a rail system other than *KWIKtrak*, make sure you have read and understood the addendum supplied with the adapted accessory.

Safe Working Load

The Voyager has been designed with a lifting capacity of 200 kg (440 lb).

WARNING: The Voyager is intended to be used for patients whose weight is within a specified safe working load. Do not attempt to lift more than the lowest weight limit indicated on the following:

- the rail system;
- the “maximum load” label on the lift;
- on the accessories;
- on the sling.

Surcharge of any of these elements may lead to a patient fall and to injuries.

Important Safety Directions

Always ensure that:

- The portable lift was installed by an approved ArjoHuntleigh contractor or installer.
- The product is used by trained caregivers.

WARNING: Before attempting a transfer, a clinical assessment of the patient’s suitability for transfer should be carried out by a qualified health professional. A transfer conducted when it should not can degrade the patient’s health condition.

- Special consideration is taken when transferring a patient who is connected to electrodes, catheters or other medical devices.
- Violent impact during transfers is avoided.
- The sling is not damaged, torn or frayed and the straps are in good condition and properly fastened.
- The lifting steps found in this manual are followed.
- All controls and safety features are used only according to the rules found in this manual. Never attempt to force a control or button on the lift.
- The charger is not stored in a shower, bath or other areas with high humidity.
- Any precautionary or instruction labels are read and those that cannot be easily read are replaced.
- The daily maintenance is carried out before using the lift.

WARNING: ArjoHuntleigh warns of possible strangulation risks related to the lifting strap or the hand control cable. Take necessary precautions to prevent these.

WARNING: This product contains small parts that might present a choking danger to children if swallowed or inhaled.

CAUTION: Keep all components of the lift clean and dry.

CAUTION: Excessive exposure of the hand control to water (or other liquid) could cause malfunction of the device.

Safety Instructions

Shock Prevention

- Do not touch or use a lift with bare conductors or a damaged power cord. If this is the case, contact your local ArjoHuntleigh agent immediately.
- Do not splash or expose the device to water or moisture.
- Check nameplate for input voltage and frequency requirements. These ones differ by country. Do not attempt to use the lift in an area that has a different voltage and frequency requirement.
- Read batteries and charger instructions carefully before using or storing them.

Fire and Explosion Prevention

- Do not place or store the battery under direct sunlight or near a heat source.
- Do not expose the batteries to flames. They might open, causing a chemical leak.
- Do not use the charger in the presence of flammable anaesthetic gases. The charger might generate a spark, which could cause an implosion.
- Do not short circuit the battery terminals.

Human and Environmental Safety Practices

- Should the battery casing crack and cause contents to come in contact with skin or clothing, rinse immediately with plenty of water.
- If contents come in contact with the eyes, rinse immediately with plenty of water and seek medical attention.
- Inhalation of the contents can cause respiratory irritation. Provide fresh air and medical attention.
- For recycling and disposal of the batteries, the rules according to the WEEE directive (Waste of Electronic and Electrical Equipment) as well as local laws and regulations must be followed. If not they may explode, leak and cause personal injury. When returning batteries, insulate their terminals with adhesive tape. Otherwise, the residual electricity in used batteries may cause fire or explosion. When disposing of any items associated with the equipment, contact the appropriate local authorities for information. Fig. 2 shows the symbols for disposal and recycling.

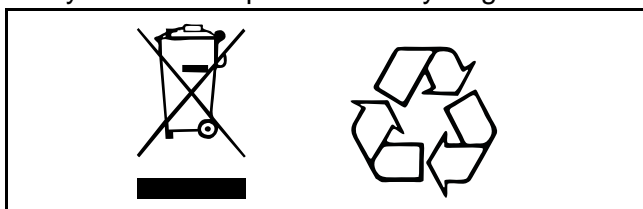

Fig. 2

Environmental Advice

When disposing of any items associated with the equipment, contact the appropriate local authorities for information.

Battery and Battery Charger Safety Practices

NOTE: Following the instructions is important to prolong the battery life.

Only use batteries designed for use with the device. If unsure, do not use the battery. Make sure it belongs to the device by comparing the battery label with the technical specifications in the *Instructions for Use*. If battery type cannot be confirmed, call your ArjoHuntleigh agent.

- Do not expose the battery or chargers to flames.
- To avoid bodily injury, do not crush, puncture, open, dismantle or otherwise mechanically interfere with the battery.
- Stop using the battery if any damage or deformation is noted.
- Be careful not to drop the battery.
- Only use the charger that has been supplied with the product.
- Do not charge the battery in an unventilated area.
- The charger must not be covered or exposed to dust.
- The charger is designed for dry areas only and for normal air humidity conditions.

Homecare Environment Considerations

WARNING: The Voyager is not intended to be operated by children. Serious injuries could occur.

NOTE: Rigorous cleaning actions should be done when the Voyager is exposed to an animal. Pet hair trapped inside the device (through the strap opening) can reduce the product performance.

Voyager Portable Lift and Charging Station

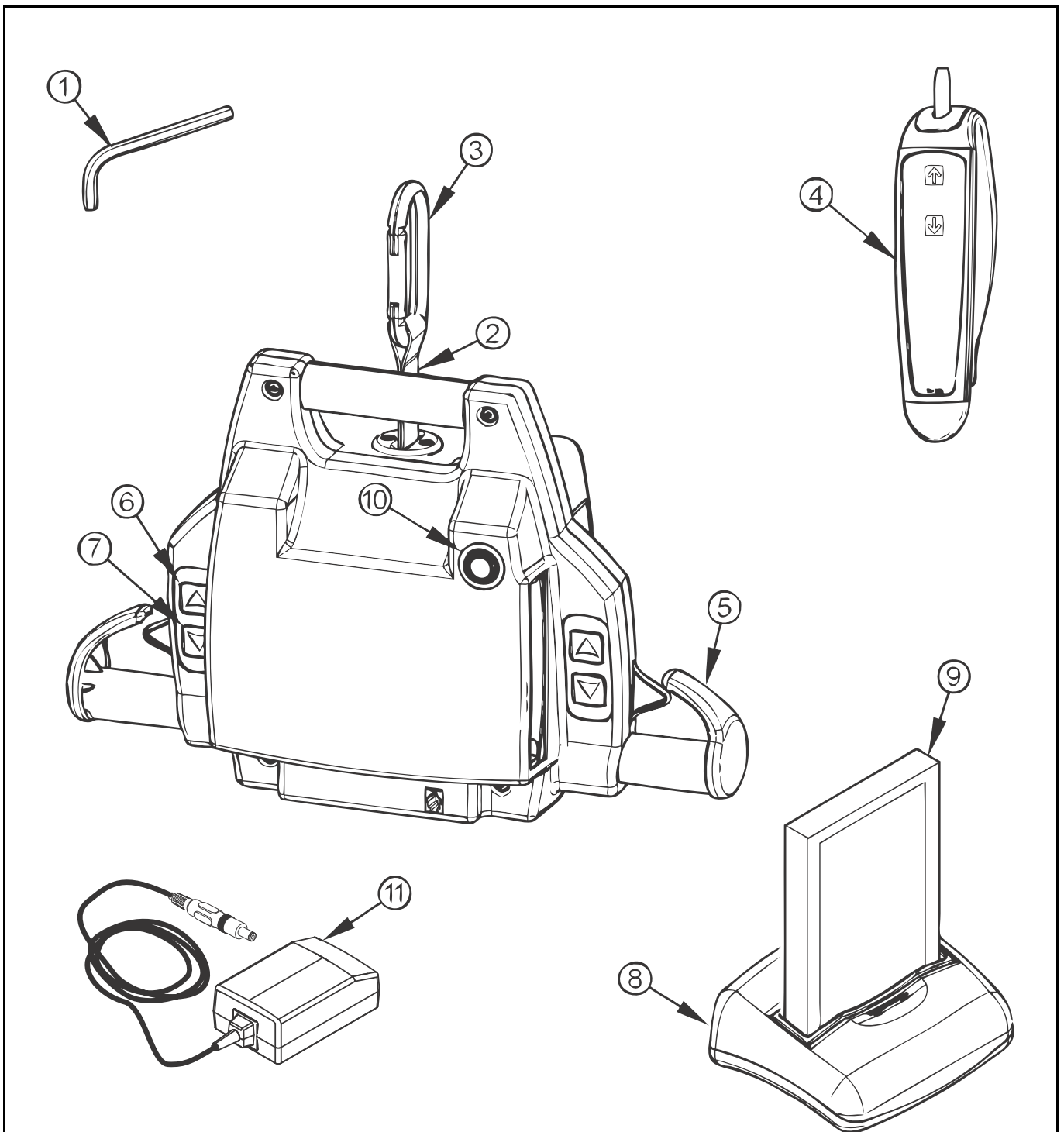

Legend

- | | | |
|---------------------------|---------------------|---|
| 1) Emergency lowering key | 5) Support | 9) Battery |
| 2) Strap | 6) UP button | 10) Emergency stop/Battery eject button |
| 3) Carabiner | 7) DOWN button | 11) Charger |
| 4) Hand Control unit | 8) Charging Station | |

Fig. 3

Parts Designation

Hand Control

The Voyager's hand control is used to operate the portable lift. Each function is described in Fig. 4. The up and down buttons raise or lower the lift.

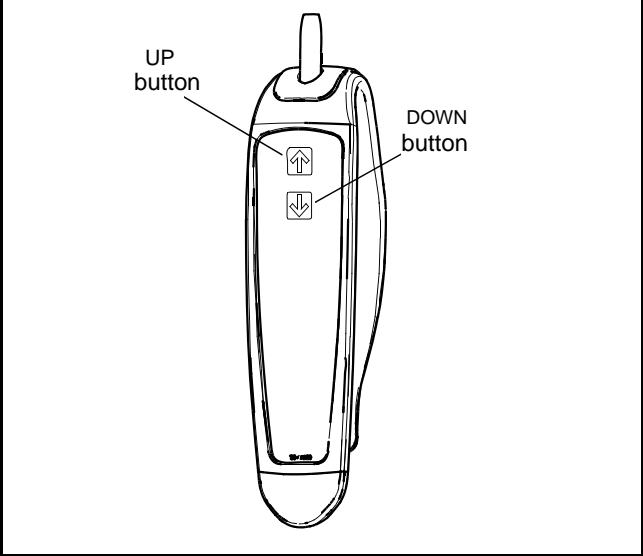

Fig. 4

Accessories

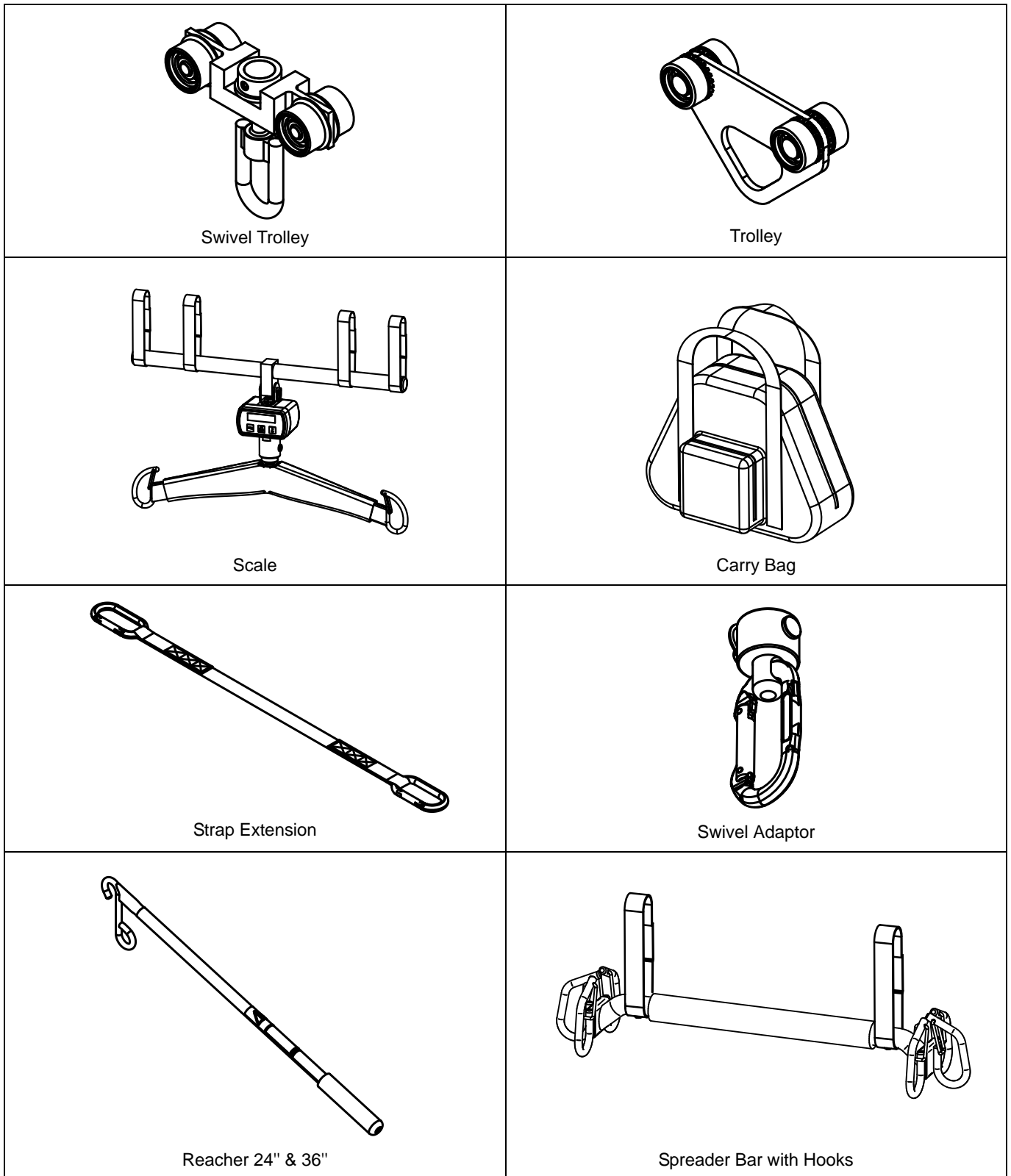

Fig. 5

Refer to your local ArjoHuntleigh agent for ordering.

WARNING: All trolleys are not compatible with all rail systems. Please contact your local ArjoHuntleigh agent to get more information.

Slings

Compatible Slings

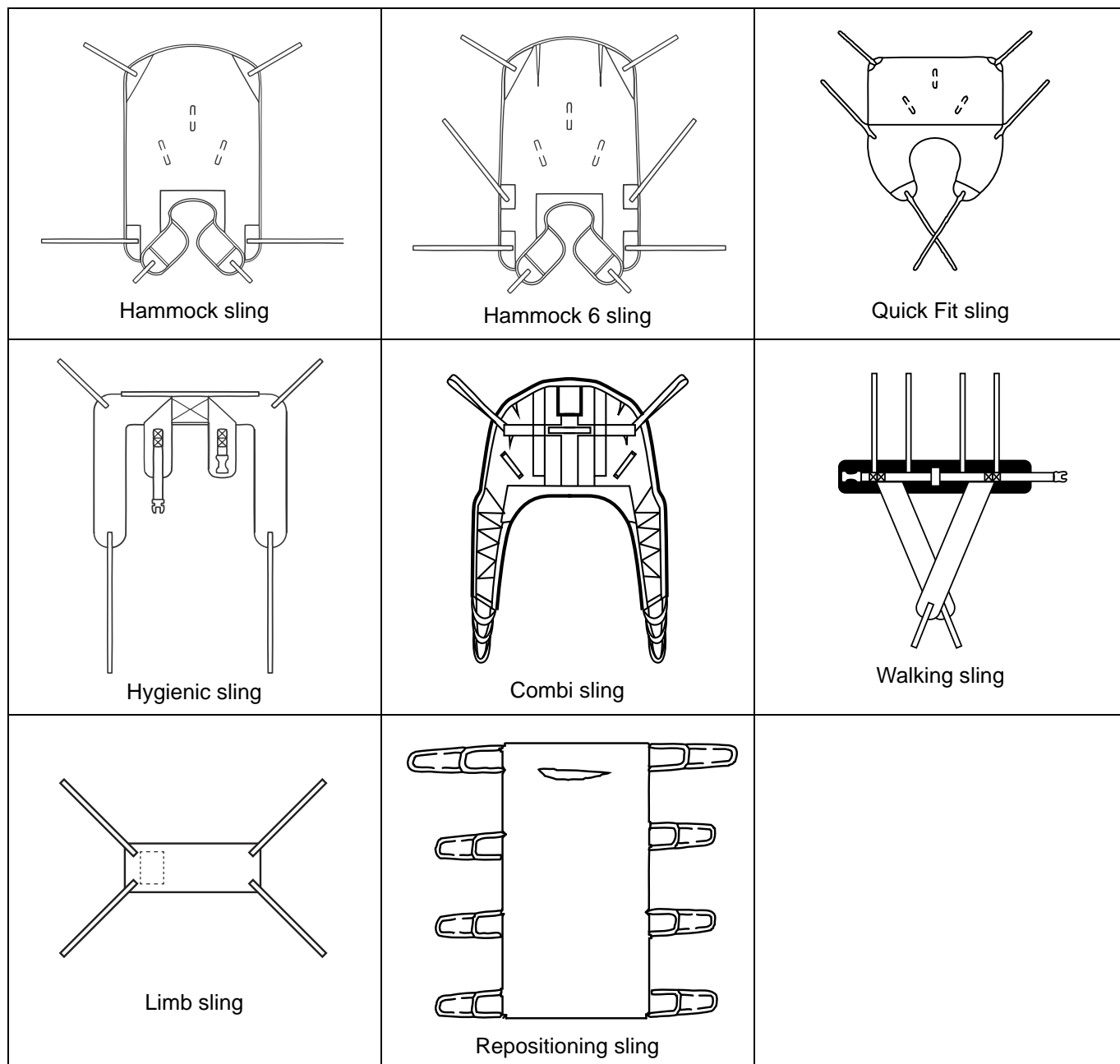

Fig. 6

Refer to your local ArjoHuntleigh agent for ordering.

How to Use the Voyager

WARNING: All rails must be closed with end stoppers or connected to other closed rail components. Before use, make sure all end stoppers are in place and secured. A wrong installation of these items might lead to a patient fall and to injuries.

WARNING: The lift must never be operated by the patient. In the unlikely case of a failure, the patient might get stuck in the unit.

Use of Slings

The two-sling supports can accommodate any of the ArjoHuntleigh loop attachment slings.

All slings are color coded for size by having a different colored edge binding or attachment strap coloring:

- Grey or Teal - Extra Extra Small - XXS
- White or Brown - Extra Small - XS
- Red - Small - S
- Yellow - Medium - M
- Green - Large - L
- Blue - Extra Large - XL
- Terracotta - Extra Extra Large - XXL

ArjoHuntleigh offers the option of a headrest for many slings if it is considered necessary for a particular patient. A range of special purpose slings is available as accessories. For these or for special size slings, contact your ArjoHuntleigh agent.

WARNING: When using ArjoHuntleigh *Flites* slings (disposable) with the Voyager, always refer to the ArjoHuntleigh *Flites* operating instructions as well as these instructions before using.

Before Approaching the Patient

Attendants should always tell the patient what they are about to do. Make sure to have on hand a sling that is of the correct model and of adequate size for transfer with the Voyager.

Before performing the transfer, it is important to evaluate the patient's general condition. For example, an agitated patient will require a more specific type of sling.

Attachment Methods

Once the loop sling has been fitted around the patient, it can be configured in three ways. With

each of the three methods described below, it is necessary to first connect each shoulder loop of the sling to both sides of the spreader bar.

Attachments Points

The attachment point designation shown here are only for the purpose of the explanations below.

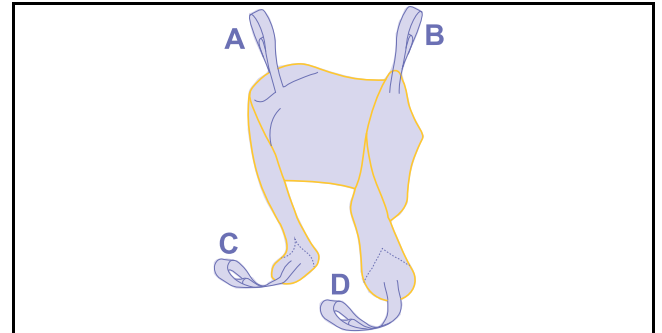

Fig. 7

Method 1 - Cross-through

(Legs closed with crossing straps)

This method is recommended for most general transfer.

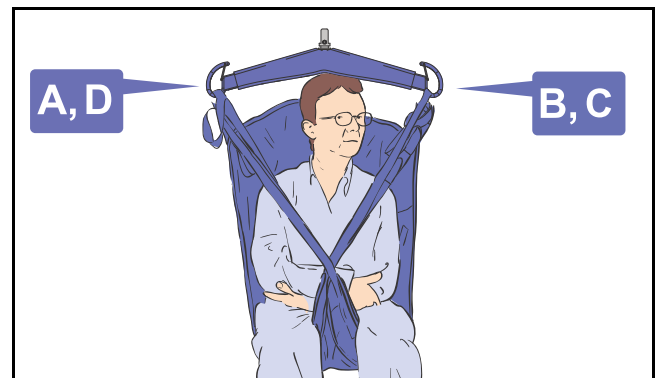

Fig. 8

Method 2 - Hammock

(Bridge, legs closed)

This method can provide a comfortable cradle for amputee patient.

It is also a useful method for patients with contractures, making it difficult to bring a sling strap between the legs.

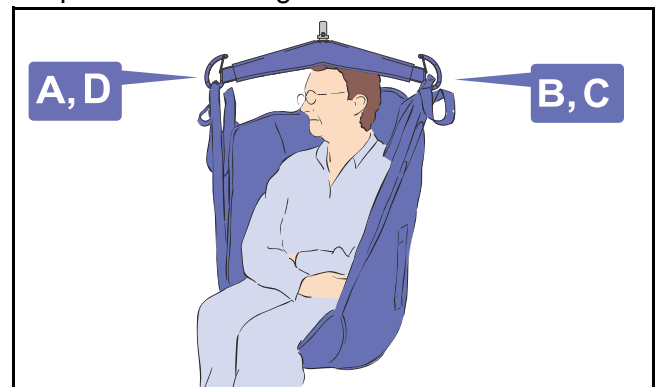

Fig. 9

WARNING: Method 2 might not be suitable for confused, combative or erratic patients as they can fall forward and get injured.

How to Use the Voyager

Method 3 - Abduction

(Legs opened with non-crossing straps)

In this method, legs are held in abduction which is convenient for toileting and hygiene care.

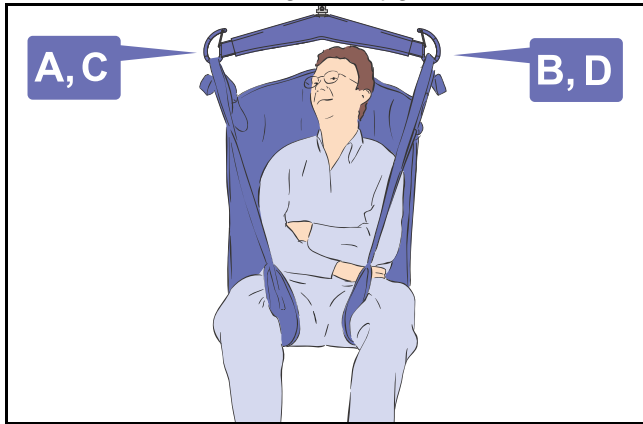

Fig. 10

WARNING: Method 3 might not be suitable for patients with no upper body control as they can slide down and almost out of the sling.

Transferring the Patient

- 1) Install the patient into the sling according to the "Installing a Patient into the Sling" section.
- 2) Take the battery out of the charger and insert it into the lift. Make sure the silver contact points go inside the lift.
- 3) Once the patient sling is installed, unwind the strap.

There are two ways to unwind the strap:

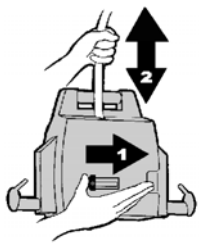

First, you can press the down button while holding tension on the strap with the other hand (there must be tension on the strap for the lift to function).

The other way is to use the "quick-release". (1) Push the knob sideways and (2) pull the strap out of the lift.

CAUTION: Push the knob completely over to ensure that the quick-release will work properly. It will not work if there is tension on the strap. Make sure the strap has some slack in it before attempting to slide the knob over. DO NOT force the knob. It should slide easily.

- 4) Attach the carabiner to the trolley in the rail.

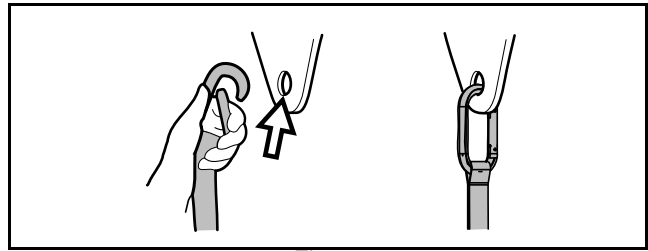

Fig. 11

- 5) Move the lift over to the patient.

WARNING: Hold the lift at all times when near a patient. The proximity of the lift near the patient's face may cause the patient some discomfort.

- 6) Lower the lift to approximately below the patient's chin level before beginning to attach the sling straps (this is to avoid the unit from making contact with the patient's face due to the movement of the lift).

For a patient in a lying position, lower the lift near the thorax, and then:

- 7) Attach the straps of the sling.

WARNING: Before lifting the patient:

- 1) Make sure that all straps are attached to the lift's supports.
- 2) Make sure the patient's arms are safely out of the way.
- 3) Make sure the sling is not caught on any obstructions (wheelchair brake or arm of chair, etc.).

If any of the above occurs, correct the problem. Any of these situations might lead to a patient fall.

- 8) Lift the patient slightly by pressing the UP control button.

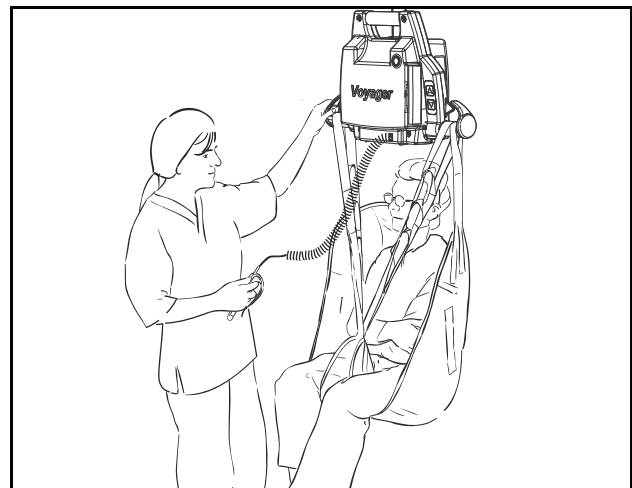
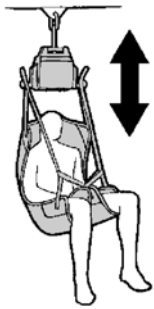

Fig. 12

How to Use the Voyager



9) Lift until the patient's buttock clears all obstacles in the transfer path, chair arm supports for example, before moving the patient. Guide the legs past any obstacle.

10) When the patient is located above the desired point of transfer and ready to be lowered, press the down button.

WARNING: A patient should never be left unattended during a transfer. In the unlikely event of a failure of the device, the caregiver must be ready to react.

11) Use the handles on the back of the sling to position the patient when transferring into a chair. Hold the handles firmly as the sling lowers and the sling will tilt back to position the patient.

12) Once the patient is properly seated and the straps are loose, remove the sling from the lift.

13) Slide the lift away from the patient.

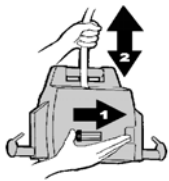

14) Unhook the lift from the trolley in the rail and use the "quick release" to wind up the strap. To do so, (1) push the knob sideways and (2) hold the strap while it winds itself into the lift.

CAUTION: When using the "quick-release", hold the strap in your hand and release the knob only when the strap is not in motion. This will prevent wear of the internal components.

15) Remove the sling from around the patient.

Emergency Lowering

The Voyager has a safety feature that allows the lift to be lowered even if the electrical system does not operate.

Located on the right side of the lift (near the sling support), the emergency lowering device is activated by the insertion of the key included with this manual.

To lower safely a patient, follow these steps, as illustrated in Fig. 13:

- 1) Find the rubber stopper and label on the side of the lift and pull it out. Do not discard it.
- 2) Move the patient over a bed or chair.

- 3) Insert the 4 mm Allen key into the opening then turn it clockwise to lower the patient. The key rotation turns the motor directly, so that for each key turn, the patient will lower slightly.

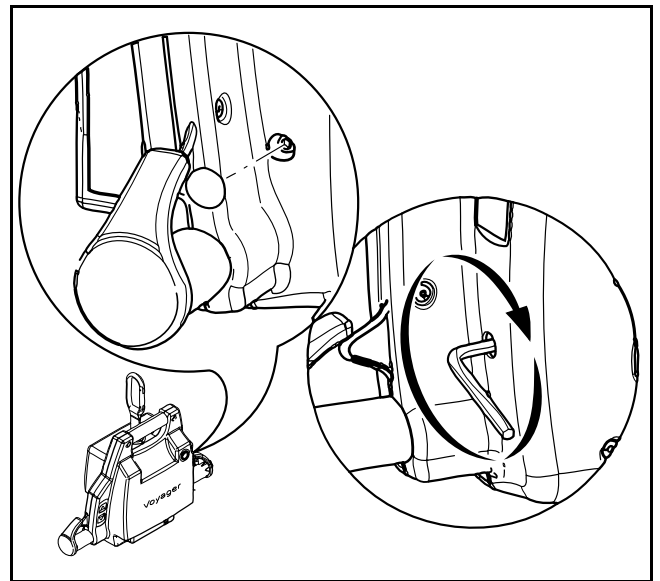

Fig. 13

CAUTION: The emergency lowering feature is to be used only in case of emergency.

- 4) Once the patient is lowered safely on a bed or into a wheelchair, remove the key from the lift and call a qualified technician to service your Voyager.

Emergency Brake

The emergency brake is an additional safety feature that automatically prevents the patient from falling in the unlikely event of a transmission or motor failure.

WARNING: After an incident has occurred and the brake was deployed, never attempt to unlock the brake or press the UP button. This may disengage the brake and make the patient fall. The emergency lowering device cannot be used.

WARNING: Never use a portable lift with the emergency brake deployed. Use other equipment to lower the patient. Forcing the lift to make it move might lead to a patient fall.

The emergency brake is intended for a single activation and therefore can only be used once. Call your ArjoHuntleigh agent to arrange for the unit to be replaced.

How to Use the Voyager

Battery Information

For safe handling and to extend the battery lifetime, please follow and remember these instructions.

CAUTION: Not following these instructions can cause short battery life.

Only use batteries designed and labelled for use with the device. When not sure, do not use the battery. Make sure the battery belongs to the device by comparing the battery label with the technical specifications in this manual. If battery type cannot be confirmed, call your ArjoHuntleigh agent.

Battery life depends on many factors: frequency of use, frequency of charging, temperature of operation, storage and storage time.

Make sure to have a replacement battery ready when needed. Have the facility department keep one in stock.

The battery included in the Voyager is 24 VDC, 2.0 Ah and rechargeable. It provides 10 to 30 transfers per battery charge.

NOTE: To prolong battery life, put the battery on charger station whenever the portable lift is not in use. If the low battery indicator beeps, make sure to recharge the batteries as soon as possible. This will extend their life.

NOTE: ArjoHuntleigh uses sealed lead-acid batteries. These ones are not affected by any memory effect. Therefore, they should not be completely drained before recharging.

Charging the Battery

WARNING: Do not operate the charger with a damaged cord or if the lift has been dropped or damaged.

Do not bend the power cord by force, or place a heavy object on it. This will damage the cord and may cause fire or electrical shock.

The steps for recharging the battery are as follows:

- 1) Eject the battery from the lift unit by pressing on the battery eject button.

NOTE: To avoid dropping the battery, keep your hand near the battery opening when pressing on the battery eject button.

- 2) Check to make sure that the green light on the charger is illuminated. Insert the battery into the charger, ensuring that the metal contact points on the battery touch the charger's contacts.

The charging indicator light (yellow) will flash while the battery is charging. When the battery is fully charged, the charging indicator light will become solid.

If the battery is fully drained it could take up to six hours to recharge.

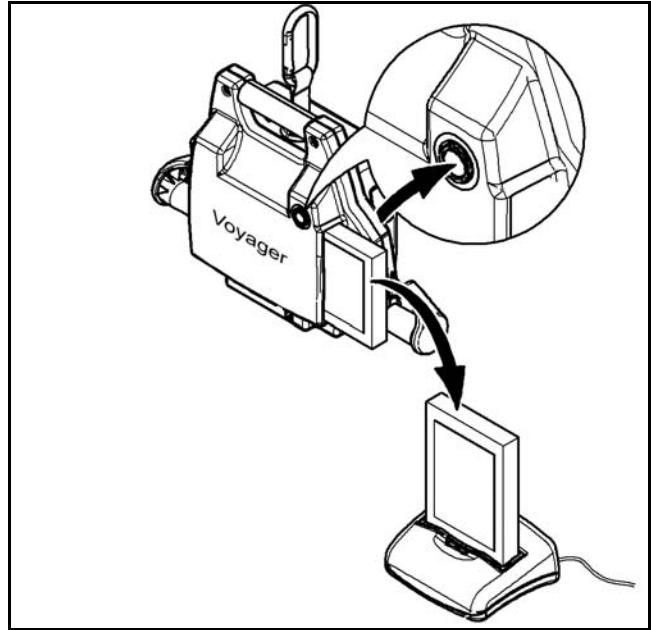

Fig. 14

When the lift is needed again, pull the battery out of the charger and gently slide it back into the Voyager portable lift. The metal contacts should be inside the lift.

The charger's power cord can remain plugged into the wall indefinitely, convenient for overnight recharging.

The battery can be left in the charger for an extended period of time without damaging either the charger or the battery.

If the green light does not go on when the charger is plugged into an electrical outlet, see the "Troubleshooting" section.

CAUTION: The lift should not remain stored for long periods of time without charging the batteries. These should be recharged at least every two weeks to maximize their life-span.

Care and Maintenance

Preventive Maintenance Schedule

The equipment is subjected to wear and tear, and the following maintenance instructions must be acted upon when specified to ensure that it remains within its original manufacturing specifications. Care and maintenance must be carried out in accordance with the preventive maintenance schedule below.

Customer obligations must be carried out by qualified personnel in accordance with the instructions in this manual.

WARNING: The maintenance described in the following checklist is the minimum that the manufacturer recommends. In some cases more frequent inspections should be carried out. Continuing to use this product without conducting regular inspections or when a fault is found will seriously compromise the safety of the user and of the patient. Service and preventative maintenance can be arranged with the manufacturer. Preventive maintenance specified in this manual can prevent accidents and reduce repair costs.

WARNING: Safety related maintenance and authorized service must be carried out by qualified personnel, fully trained in servicing procedures by ArjoHuntleigh, and equipped with correct tools and proper documentation, including Parts List and Service Manual. Failure to meet these requirements could result in injuries and/or unsafe equipment.

User Inspections

Action/Check	INITIALLY	BEFORE EVERY USE	EVERY 2 MONTHS	EVERY 4 MONTHS	EVERY YEAR	EVERY 2 YEARS
Lift device						
Inspect for missing hardware, broken enclosure or casing not properly aligned.	X	X			X	
Inspect the carabiner at the top of the strap to ensure that it is properly attached.		X				
Inspect strap for wear.		X	X			
Recharging battery.		X				
Inspect the sling supports on the lift for damage or cracks.					X	
Inspect wheels in rail for damage, rust or cracks. Replace if damaged.					X	
Clean the rail.				X		
Overall inspection by authorized personnel.					X	
Inspect carabiner for damage or cracks					X	
Verify emergency stop button.				X		
Verify emergency lowering device.				X		

Care and Maintenance

Action/Check	INITIALLY	BEFORE EVERY USE	EVERY 2 MONTHS	EVERY 4 MONTHS	EVERY YEAR	EVERY 2 YEARS
Sling and hardware						
Check all sling attachments for sign of wear.		X				
Inspect sling material for wear or deterioration.		X				
Inspect sling straps for wear.		X				
Inspect for any defects or loose threads in the "stitched areas".		X				
Cleaning sling as indicated on the tag.	WHEN NECESSARY					

Inspections by an Authorized Service Technician

Action/Check	INITIALLY	BEFORE EVERY USE	EVERY 2 MONTHS	EVERY 4 MONTHS	EVERY YEAR	EVERY 2 YEARS
Authorized Service						
Replace strap.						X
Inspect the welding aspect on the frame to detect cracks.					X	
Inspect transmission.					X	
Inspect connecting joints for proper attachment.					X	
Verify that the emergency brake on the drum is turning freely.					X	
Verify emergency devices for good functioning.					X	
Load test with SWL (maximum working capacity).					X	

WARNING: Always reinstall the rail end stoppers (if removed) after servicing. These stoppers are part of safety feature. Not having them in place can cause the trolley to fall off the rail and a patient fall.

WARNING: Make sure the trolley is compatible with the stoppers and rail system.

Cleaning the Lift

NOTE: It is recommended to clean the lift and its accessories between each patient use.

Removing visible residues:

- 1) Use a cloth soaked with water.
- 2) Remove visible residues from the lift and its accessories (sling, handset, strap) from top to bottom.

Cleaning:

- 1) To clean the Voyager and its accessories, spray cleaning fluid on the product, and use a brush (to remove any deposits).
- 2) Use a clean damp cloth with clear water to wipe off all spots of cleaning fluids.
- 3) If cleaning fluid cannot be removed on some hard-to-access parts, spray water on the affected part and wipe off with disposable towels/cloth. Repeat until all of the cleaning fluid has been removed.
- 4) Repeat steps 1 to 3 as necessary.
- 5) Let the parts dry.

NOTE: Pay special attention to areas pointed in . These are most likely to enclose germs. Use a smaller brush and/or cotton swab to reach them.

CAUTION: Do not drench the product, as this could damage electrical components and cause internal corrosion.

If a hot air dryer is used to dry the lift, the temperature must not exceed 80°C (176 °F).

Do not use petroleum-based solvents, as this may damage plastic parts.

Voyager's Special Areas to Clean

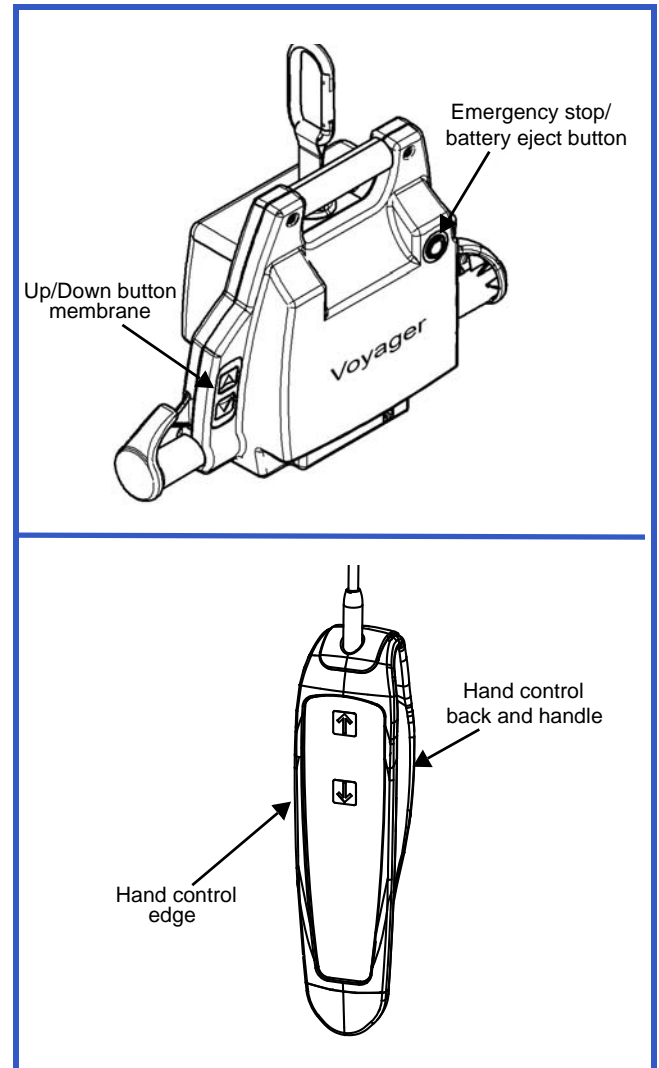

Fig. 15

To ensure a better rolling surface for the trolley wheels, clean the inside of the rail every 4 months. To do so, insert a damp cloth in the opening and slide it from one end of the rail to the other.

Care and Maintenance

Strap Inspection

If the strap is damaged or shows signs of wear or discoloration, the acceptable load on the strap before rupture can drop rapidly and present a danger for the patient or caregiver. ArjoHuntleigh recommends a thorough inspection of the straps every 2 months as follows:

- 1) Completely unwind the strap.
- 2) Look for any signs of wear or discoloration (see Fig. 16 below).

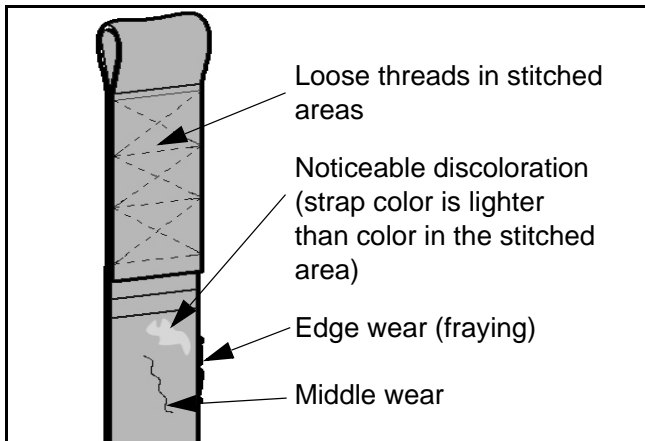

Fig. 16

WARNING: If there is any sign of wear as indicated above or any other visual defects, stop using the lift and call your local ArjoHuntleigh agent to have the strap replaced.

Continuing to use the lift with a damaged strap can compromise the safety of the caregiver or the patient.

The manufacturer recommends changing the strap at least every 2 years or every 2850 cycles—which ever comes first.

Handling and Storage

Avoid violent impacts while transporting the lift.

The lift should not remain stored for long periods of time without recharging the battery.

NOTE: Even if the lift is not used, ArjoHuntleigh recommends charging the battery at least every 2 weeks. This will prevent premature aging of battery.

If you store or ship the Voyager, ensure that the power is turned off (push the battery eject button) beforehand.

Battery Replacement

Replace the batteries when there is a noticeable reduction in the number of transfers that can be done between charges. If you hear the Voyager beeping and notice a red light flashing, see the instructions in the “Troubleshooting” section to determine if there is a problem with the batteries.

For battery replacement, contact your local ArjoHuntleigh agent.

CAUTION: Do not attempt to use batteries that were not supplied by ArjoHuntleigh. These batteries are specially designed for ArjoHuntleigh charging systems. Attempting to use unapproved batteries may seriously damage the lift and/or the charger.

Sling Inspection and Care

See the documentation included with your sling.

Annual Inspection

The Voyager and its accessories must be inspected annually by a qualified technician.

WARNING: The Voyager and accessories must be serviced every 12 months as a minimum requirement. Moving parts can be affected by wear. Not servicing the product may lead to patient fall, causing injuries.

Troubleshooting

PROBLEM	VERIFY
<p>The unit does not work when you press the UP or DOWN buttons on the hand control.</p>	<ul style="list-style-type: none"> • Make sure the hand control is plugged correctly into the unit. • Use the control switches directly on the unit. If they are working, it indicates a problem with the hand control; you would then need to change the hand control.
<p>The unit does not work when you press the UP or DOWN buttons on both sides of the lift.</p>	<ul style="list-style-type: none"> • Is the battery charged and correctly installed? Ensure the battery is inserted into the lift with the metal contact points inside the lift. Place the battery into the charger and check the light on the charger. If the yellow light keeps flashing, leave the battery in the charger for approximately two hours. • Is the “quick release” knob completely to the left (locked) position? If not, the lift will not operate. Tighten the tension on the strap to help move the “quick release” knob. • Is there tension on the strap? The “anti-crush” feature will prevent the lift from working if there is no tension. If all of the previous points have been checked without success, you probably have a motor or electrical problem. You need to call your ArjoHuntleigh agent.
<p>The unit starts and stops repetitively.</p>	<ul style="list-style-type: none"> • If the load is more than safe working load, the unit will not work due to an overload protection on the motor. • Has the lift been making a “beeping” sound? The battery is low and needs to be charged.
<p>The unit emits a “beep” during use. The unit may stop lifting but you can still lower it.</p>	<ul style="list-style-type: none"> • Battery is low. Recharge it.
<p>Battery is always dead after only a few transfers (3 to 5).</p>	<ul style="list-style-type: none"> • Replace battery with a new one, the life of the current one is probably nearly over. (See “Battery Information” section).
<p>The light on the charger shows a solid yellow when the battery is inserted, yet the lift will only do 1 or 2 transfers.</p>	<ul style="list-style-type: none"> • Battery has either been dropped or damaged in some other way. Replace the battery.
<p>The charger’s green light is not illuminated.</p>	<ul style="list-style-type: none"> • Is the charger plugged into a standard outlet? Try plugging the charger into another outlet to see if it will work. • If the green light will still not illuminate, contact your local agent.

Troubleshooting

PROBLEM	VERIFY
When battery is inserted into the charger, the yellow light does not flash or illuminate solid.	<ul style="list-style-type: none"> • Check the orientation of the battery. The contact points should be inside the charger. • If the yellow charge light will still not illuminate, contact your local agent.
The light does not illuminate when there are batteries correctly installed	<ul style="list-style-type: none"> • Make sure that the charger is correctly plugged into the AC outlet, and that the green light on the clip-on charging station is on. • Make sure that there is contact between the contact blades of the lift and the contact plates of the charging station. • Check the power of the AC outlet on the wall. • If the charge station's green light does not light up, contact your local ArjoHuntleigh agent.
The battery does not slide into the lift.	<ul style="list-style-type: none"> • Check if there is any damage to the battery that would interfere in the lift battery's slot. IF THERE IS DAMAGE - DO NOT USE THE BATTERY. • Try to slide in another battery to see if there is any damage in the lift battery's slot. If so, call your ArjoHuntleigh agent. If not, discard the damaged battery.
Cannot remove battery from the lift	<ul style="list-style-type: none"> • See "How to Use the Voyager" section under "Charging the Battery" to know how to correctly remove the battery. • If the battery will not come out, tilt the lift to the side so that the battery opening is under the lift. With your hand guarding the opening for the battery, press the eject button on the front of the Voyager while gently tapping the lift to help jolt the battery out of the lift. Once the battery is removed, discard and replace it. • If you cannot remove the battery after trying the above, contact your local agent.

Labels on the Lift

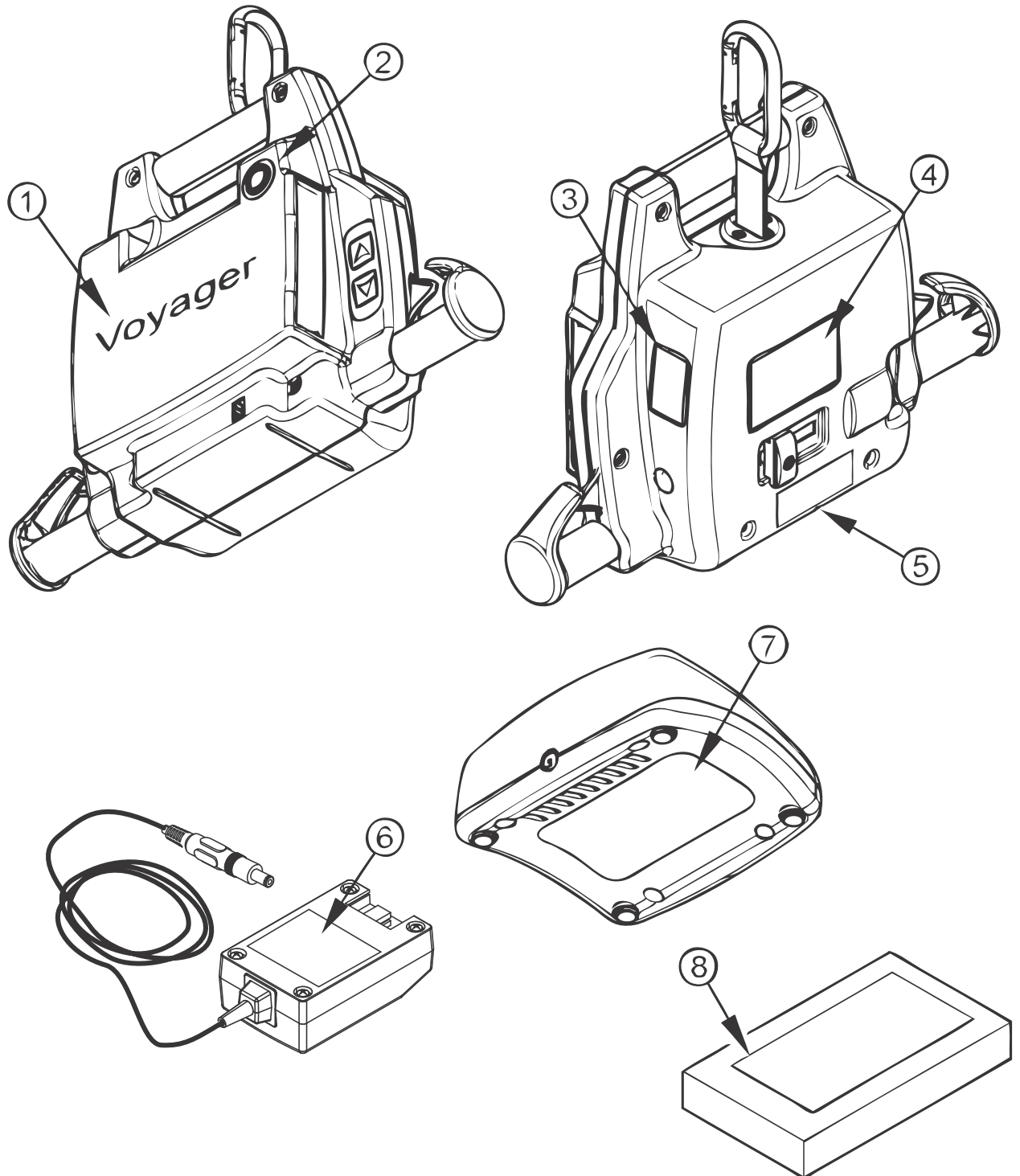

- 1) Product name
- 2) Emergency stop
- 3) Emergency lowering
- 4) Quick release
- 5) Serial number
- 6) Charger Information
- 7) Charging station information
- 8) Battery information

Fig. 17

Technical Specifications

PRODUCT INFORMATION	
Weight, complete	5.45 kg (12 lb)
Lifting capacity (SWL)	200 kg (440 lb)
Strap length	2200 mm (88 in)
Lifting speed	4.3 cm/s (1.7 in/s)
Operating force of control	< 5 N
ELECTRICAL	
Duty cycle	Max 10%, 6 min/hr, (max. 1 min. continuous)
Rating	24 VDC, 10 A max.
Noise level for either raising or lowering, with or without load	70 dBAm _{ax} .
Medical equipment	Type BF protection against electrical shock in accordance with IEC 60601-1
The Voyager is compliant with CAN/CSA C22.2 No. 601.1 (SUP1+AM2), UL 60601 1, CAN/CSA-C22.2 No. 60601-1-08, ANSI/AAMI ES60601-1: 2005, and tested according to ISO 10535: 2006.	
WARNING: Wireless communications equipment such as wireless home network devices, mobile phones, cordless telephones and their base stations, walkie-talkies, etc. can affect the Voyager and should be kept at least 2.3 m away from it. Cables from potentially strong sources of electromagnetic fields should not be placed near the unit.	
BATTERY AND CHARGER UNIT	
Battery	Qty: 1 x rechargeable 24 VDC, 2.0 Ah
Battery capacity	Provides up to 30 transfers with a load of 80 kg (176 lb)
Degree of protection - Hand control	IPX7
Degree of protection - Voyager	IPX0 - Keep dry
Lift - protection class - shock prevention	Internally powered equipment
Battery charger input	100-240 VAC, 50-60 Hz, 50 VA
Battery charger output	24 VDC, 24 VA, 28.1 Vdc, 1 A
Battery charger safety protection	Class 2, double insulated
OPERATION CONDITIONS	
Ambient temperature range	+5 °C to +40 °C (+41 °F to +104 °F)
Relative humidity range	15 % to 93 %, non-condensing
Atmospheric pressure range	700 hPa to 1060 hPa (max. 2000 m)
STORAGE CONDITIONS	
Ambient temperature range	-25 °C to +70 °C (-13 °F to +158 °F)
Relative humidity range	Up to 93 %, non-condensing
Atmospheric pressure range	500 hPa to 1060 hPa
WARNING: This equipment is not suitable in the presence of flammable anesthetic mixtures with air or oxygen, or with nitrous oxide. Using the Voyager in this environment might lead to an explosion. The lift might create some spark internally and ignite the gaz.	
RECYCLING	
Battery	Sealed lead-acid, rechargeable, recyclable
Package	Cardboard recyclable
The lift	Separated and recycled, according to the European Directive 2002/96/EG (WEEE).

Technical Specifications

Lift Dimensions

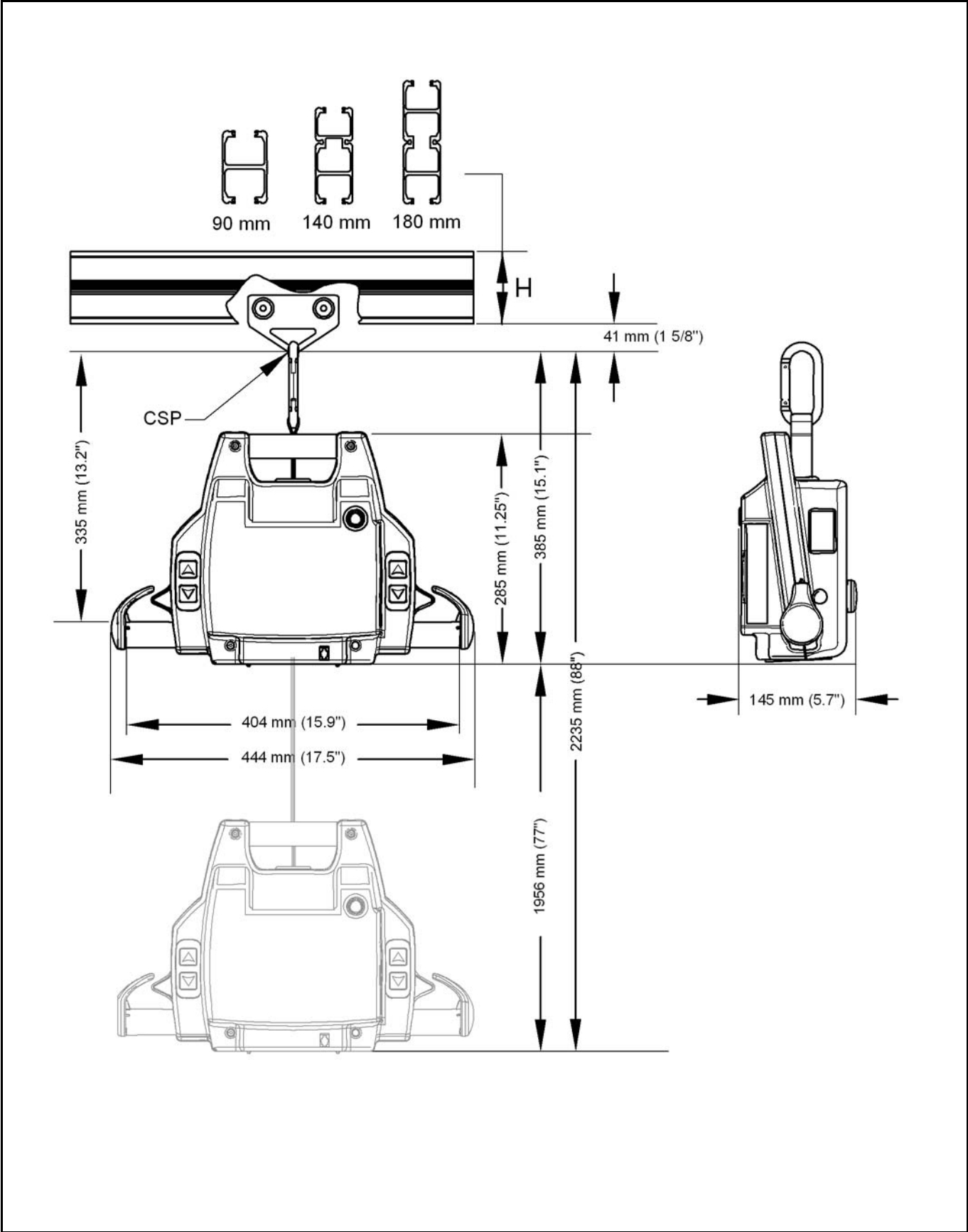

Fig. 18

Electromagnetic Compatibility

Electromagnetic Compliance

The Voyager has been tested for compliance with current regulatory standards regarding its capacity to block EMI (electromagnetic interference) from external sources.

Nonetheless, some procedures can help reduce electromagnetic interferences:

- Use only ArjoHuntleigh cables and spare parts to avoid increased emissions or decreased immunity which can compromise the correct functioning of the equipment.
- Ensure that other devices in patient-monitoring and/or life-support areas comply to accepted emissions standards.
- Maximize the distance between electro-medical devices. High-powered devices may produce EMI that can affect the ceiling lift. Refer to separation distance table further on in this document.

For more information on how to manage the unit's RF electromagnetic environment, please consult the *AMI TIR 18-1997 - Guidance on Electromagnetic Compatibility of Medical Devices for Clinical/Biomedical Engineers*.

Electromagnetic Emissions

Guidance and Manufacturer's Declaration - Electromagnetic Emissions - For all Equipment and Systems		
The Voyager is intended for use in the electromagnetic environment indicated below. The customer or the user of the Voyager should assure that it is used in such an environment.		
Emissions test	Compliance	Electromagnetic environment - guidance
RF emissions CISPR 11	Group 1	The Voyager uses RF energy only for its internal function. Therefore, its RF emissions are very low and are not likely to cause any interference in nearby electronic equipment.
RF emissions CISPR 11	Class B	The Voyager is suitable for use in all establishments, including domestic establishments and those directly connected to the public low-voltage power supply network that supplies buildings used for domestic purposes.
Harmonic emissions IEC 61000-3-2	Not applicable	
Voltage fluctuations/flicker emissions IEC 61000-3-3	Not applicable	

Electromagnetic Compatibility

Electromagnetic Immunity

Guidance and Manufacturer's Declaration - Electromagnetic Immunity - For all Equipment and Systems			
The Voyager is intended for use in electromagnetic environment specified below. The customer or the user of the Voyager should assure that it is used in such an environment.			
Immunity test	IEC 60601 test level	Compliance level	Electromagnetic environment - Guidance
Electrostatic discharge (ESD) IEC 61000-4-2	±6 kV contact ±8 kV air	±6 kV contact ±8 kV air	Floors should be wood, concrete or ceramic tile. If floors are covered with synthetic material, the relative humidity should be at least 30%.
Electrical fast transient/burst IEC 61000-4-4	±2 kV for power supply lines ±1 kV for input/output lines	Not applicable ±1 kV for input/output lines	Mains power quality should be that of a typical commercial or hospital environment.
Surge IEC 61000-4-5	±1 kV differential mode ±2 kV for input/output	Not applicable	Mains power quality should be that of a typical commercial or hospital environment.
Voltage dips, short interruptions and voltage variations on power supply input lines IEC 61000-4-11	<5% <i>UT</i> (>95% dip in <i>UT</i>) for 0.5 cycle 40% <i>UT</i> (60% dip in <i>UT</i>) for 5 cycles 70% <i>UT</i> (30% dip in <i>UT</i>) for 25 cycles <5% <i>UT</i> (>95% dip in <i>UT</i>) for 5 sec.	Not applicable	Mains power quality should be that of a typical commercial or hospital environment.
Power frequency (50/60 Hz) magnetic field IEC 61000-4-8	3 A/m	3 A/m	Power frequency magnetic fields should be at levels characteristic of a typical location in a typical commercial or hospital environment.
NOTE: <i>UT</i> is the AC mains voltage prior to application of the test level.			

Electromagnetic Compatibility

(continued)

Guidance and Manufacturer's Declaration - Electromagnetic Immunity - For Equipment and Systems that are Not Life-Supporting			
Immunity test	IEC 60601 test level	Compliance level	Electromagnetic environment - guidance
Conducted RF IEC 61000-4-6	3 Vrms 150 kHz to 80 Mhz	3 Vrms 150 kHz to 80 Mhz	<p>Portable and mobile RF communications equipment should be used no closer to any part of the Voyager, including cables, than the recommended separation distance calculated from the equation applicable to the frequency of the transmitter.</p> <p>Recommended separation distance</p> $d = \left[\frac{3.5}{3} \right] \sqrt{P} \quad 150 \text{ KHz to } 80 \text{ MHz}$ $d = \left[\frac{3.5}{10} \right] \sqrt{P} \quad 80 \text{ MHz to } 800 \text{ MHz}$ $d = \left[\frac{7}{10} \right] \sqrt{P} \quad 800 \text{ MHz to } 2.5 \text{ GHz}$
Radiated RF IEC 61000-4-3	3 V/m 80 MHz to 2.5 GHz	10 V/m 80 MHz to 2.5 GHz	<p>where P is the maximum output power rating of the transmitter in watts (W) according to the transmitter manufacturer and d is the recommended separation distance in meters.</p> <p>Field strengths from fixed RF transmitters, as determined by an electromagnetic site survey, ^(a) should be less than the compliance level in each frequency range. ^(b)</p> <p>Interference may occur in the vicinity of equipment marked with the following symbol:</p> 
NOTE 1: At 80 MHz and 800 MHz, the higher frequency range applies.			
NOTE 2: These guidelines may not apply in all situations. Electromagnetic propagation is affected by absorption and reflection from structures, objects and people.			
<p>(a) Field strengths from fixed transmitters, such as base stations for radio (cellular/cordless) telephones and land mobile radios, amateur radio, AM and FM radio broadcast and TV broadcast cannot be predicted theoretically with accuracy. To assess the electromagnetic environment due to fixed RF transmitters, an electromagnetic site survey should be considered. If the measured field strength in the location in which the Voyager is used exceeds the applicable RF compliance level above, the Voyager should be observed to verify normal operation. If abnormal performance is observed, additional measures may be necessary, such as reorienting or relocating the Voyager.</p>			
<p>(b) Over the frequency range 150 kHz to 80 MHz, field strengths should be less than 3 V/m.</p>			

Electromagnetic Compatibility

(continued)

Recommended Separation Distance Between - Portable and Mobile RF Communications Equipment and the Voyager for Equipment and Systems that are not Life-Supporting			
Recommended separation distances between portable and mobile RF communications equipment and the Voyager.			
The Voyager is intended for use in an electromagnetic environment in which radiated RF disturbances are controlled. The customer or the user of the Voyager can help prevent electromagnetic interference by maintaining a minimum distance between portable and mobile RF communication equipment (transmitters) and the Voyager as recommended below, according to the maximum output power of the communications equipment.			
Rated maximum output power of transmitter W	Separation distances according to frequency of transmitter m		
	150 kHz to 80 MHz	80 MHz to 800 MHz	800 MHz to 2.5 GHz
	$d = \left[\frac{3.5}{3} \right] \sqrt{P}$	$d = \left[\frac{3.5}{10} \right] \sqrt{P}$	$d = \left[\frac{7}{10} \right] \sqrt{P}$
0.01	0.12	0.12	0.24
0.1	0.37	0.37	0.74
1	1.17	1.17	2.34
10	3.69	3.69	7.38
100	11.67	11.67	23.34
For transmitters rated at a maximum output power not listed above, the recommended separation distance d in metres (m) can be estimated using the equation applicable to the frequency of the transmitter, where P is the maximum output power rating of the transmitter in watts (W) according to the transmitter manufacturer.			
NOTE 1: At 80 MHz and 800 MHz, the separation distance for the higher frequency range applies.			
NOTE 2: These guidelines may not apply in all situations. Electromagnetic propagation is affected by absorption and reflection from structures, objects and people.			

AUSTRALIA

ArjoHuntleigh Pty Ltd
78, Forsyth street
O'Connor
AU-6163 Western Australia
Tel: +61 89337 4111
Free: +1 800 072 040
Fax: + 61 89337 9077

BELGIQUE / BELGIË

ArjoHuntleigh NV/SA
Evenbroekveld 16
B-9420 ERPE-MERE
Tél/Tel: +32 (0) 53 60 73 80
Fax: +32 (0) 53 60 73 81
E-mail: info@arjohuntleigh.be

CANADA

ArjoHuntleigh
90 Matheson Boulevard West
Suite 300
MISSISSAUGA, ON, L5R 3R3
Tel/Tél: +1 905 238 7880
Free: +1 800 665 4831 Institutional
Free: +1 800 868 0441 Home Care
Fax: +1 905 238 7881
E-mail: info.canada@arjohuntleigh.com

ČESKÁ REPUBLIKA

ArjoHuntleigh s.r.o.
Hlinky 118
CZ- 603 00 BRNO
Tel: +420 549 254 252
Fax: +420 541 213 550

DANMARK

ArjoHuntleigh A/S
Vassingerødvej 52
DK-3540 LYNGE
Tel: +45 49 13 84 86
Fax: +45 49 13 84 87
E-mail: info.dk@arjohuntleigh.com

DEUTSCHLAND

ArjoHuntleigh GmbH
Peter-Sander-Strasse 10
D-55252 MAINZ-KASTEL
Tel: +49 (0) 6134 186 0
Fax: +49 (0) 6134 186 160
E-mail: info-de@arjohuntleigh.com

ΕΛΛΑΔΑ

C. Psimitis Co Ltd
Dimitriou Andr. 59
GR-16121 KAISARIANI ATTIKIS
Τηλ: 21 0724 36 68
Φάξ: 21 0721 55 53

ESPAÑA

ArjoHuntleigh Ibérica S.L.
Ctra. de Rubí, 88 1ª planta - A1
08173 Sant Cugat del Vallés
ES- BARCELONA 08173
Tel: +34 93 583 11 20
Fax: +34 93 583 11 22
E-mail: info.es@arjohuntleigh.com

FAR EAST

ARJO Far East Limited
Unit 3A, 4/F., block B Hoi Luen
Industrial Centre
55 Hoi Yuen Road,
Kwun Tong, Kowloon
HONG KONG
Tel: +852 2508 9553
Fax: +852 2508 1416

FRANCE

ArjoHuntleigh SAS
2 Avenue Alcide de Gasperi
CS 70133
59436 RONCQ CEDEX
Tél: +33 (0) 3 20 28 13 13
Fax: +33 (0) 3 20 28 13 14
E-mail : info.france@arjohuntleigh.com

INTERNATIONAL

ArjoHuntleigh International Ltd.
ArjoHuntleigh House
Houghton Hall Park
Houghton Regis
UK-DUNSTABLE LU5 5XF
Tel: +44 (0) 1582 745 800
Fax: +44 (0) 1582 745 866
E-mail:
international@ArjoHuntleigh.com

ITALIA

ArjoHuntleigh S.p.A.
Via di Tor Vergata 432
00133 ROMA - ITALIA
Tel: +39 (0) 6 87426211
Fax: +39 (0) 6 87426222
E-mail: Italy.promo@arjohuntleigh.com

NEDERLAND

ArjoHuntleigh Nederland BV
Biezenwei 21
4004 MB TIEL
Postbus 6116
4000 HC TIEL
Tel: +31 (0) 344 64 08 00
Fax: +31 (0) 344 64 08 85
E-mail: info.nl@arjohuntleigh.com

NEW ZEALAND

ArjoHuntleigh Ltd
41 Vestey Drive
Mount Wellington
AUCKLAND 1060
Tel: +64 (0) 9 573 5344
Free Call: 0800 000 151
Fax: +64 (0) 9 573 5384
E-mail: nz.info@ArjoHuntleigh.com

NORGE

ArjoHuntleigh Norway AS
Ryenstubben 2
NO-0679 OSLO
Tel: +47 22 08 00 50
Faks: +47 22 08 00 51
E-mail: no.kundeservice@arjohuntleigh.com

POLSKA

ArjoHuntleigh Polska Sp. z o.o.
ul. Ks Piotra Wawrzyniaka 2
PL 62-052 KOMORNIKI (Poznan)
Tel: +48 61 662 15 50
Fax: +48 61 662 15 90
E-mail: arjo@arjohuntleigh.com

PORTUGAL

ArjoHuntleigh em Portugal:
MAQUET Portugal, Lda. (Distribuidor Exclusivo)
Rua Poeta Bocage n.º 2 - 2G
1600-233 Lisboa, Portugal
Tel: +351 214 189 815
Fax: +351 214 177 413
E-mail: Portugal@arjohuntleigh.com

SUISSE / SCHWEIZ

ArjoHuntleigh AG
Fabrikstrasse 8
Postfach
4614 Hägendorf,
Tél/Tel: +41 (0) 61 337 97 77
Fax: +41 (0) 61 311 97 42

SUOMI

ArjoHuntleigh OY
Vanha Porvoontie 229
FI-01380 VANTAA
Puh: +358 9 4730 4320
Faksi: +358 9 4730 4999

SVERIGE

ARJO Scandinavia AB
Verkstadsvägen 5
Box 61
SE-241 21 ESLÖV
Tel: +46 (0) 10-335 45 00
Fax: +46 (0) 413-138 76
E-mail: kundservice@arjohuntleigh.com

UNITED KINGDOM

ArjoHuntleigh UK
ArjoHuntleigh House
Houghton Hall Park
Houghton Regis
UK-DUNSTABLE LU5 5XF
Tel: +44 (0) 1582 745 700
Fax: +44 (0) 1582 745 745
E-mail:
sales.admin@ArjoHuntleigh.com

USA

ArjoHuntleigh Inc.
2349 W Lake Street Suite 250
Addison, IL 60101
Tel: +1 630 307 2756
Free: +1 800 323 1245 Institutional
Free: +1 800 868 0441 Home Care
Fax: +1 630 307 6195
E-mail: us.info@ArjoHuntleigh.com

ÖSTERREICH

ArjoHuntleigh GmbH
Dörrstrasse 85
AT-6020 INNSBRUCK
Tel: +43 (0) 512 204 160 0
Fax: +43 (0) 512 204 160 75

ARJOHUNTLEIGH

GETINGE GROUP

GETINGE GROUP is a leading global provider of products and systems that contribute to quality enhancement and cost efficiency within healthcare and life sciences. We operate under the three brands of **ArjoHuntleigh**, **GETINGE** and **MAQUET**. **ArjoHuntleigh** focuses on patient mobility and wound management solutions. **GETINGE** provides solutions for infection control within healthcare and contamination prevention within life sciences. **MAQUET** specializes in solutions, therapies and products for surgical interventions and intensive care.

www.ArjoHuntleigh.com



ArjoHuntleigh AB
Verkstadsvägen 5
241 38 Eslöv
SWEDEN



0 0 1 . 0 8 0 7 5 . E N