

ARJOHUNTLEIGH

GETINGE GROUP

Voyager Portable

Technical Manual

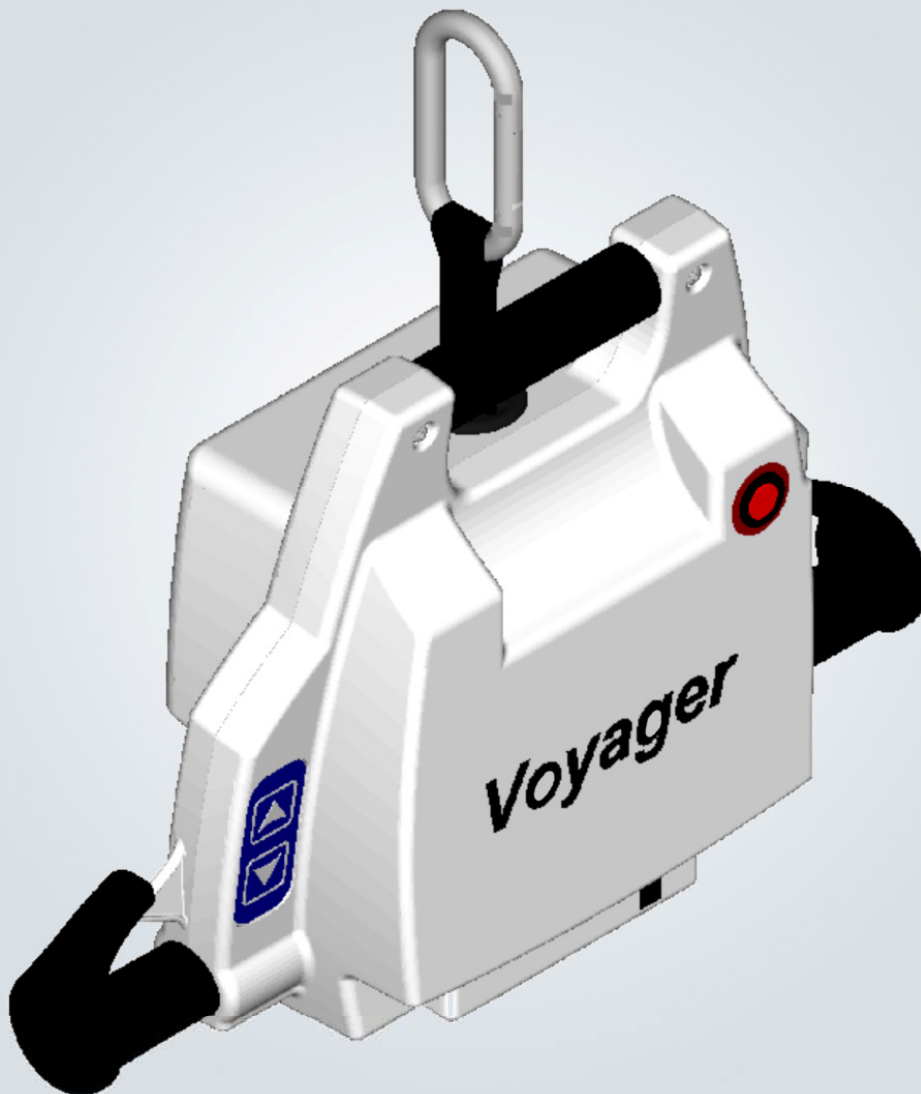

CE

Design Policy and Copyright

® and ™ are trademarks belonging to the ArjoHuntleigh group of companies.

© ArjoHuntleigh 2012.

As our policy is one of continuous improvement, we reserve the right to modify designs without prior notice.

The content of this publication may not be copied either whole or in part without the consent of ArjoHuntleigh.

TABLE OF CONTENTS

INTRODUCTION	4
HOW TO USE THIS MANUAL	4
EQUIPMENT IDENTIFICATION.....	4
RECEIPT OF EQUIPMENT	4
KEY TO SYMBOLS.....	4
SWL	4
SAFETY INSTRUCTIONS AND WARNINGS	5
DESCRIPTION OF EQUIPMENT	7
LIFT UNIT	7
WHAT'S INCLUDED	7
PARTS DESCRIPTION	7
DIMENSION	7
OPERATION	8
HOW TO USE THE VOYAGER PORTABLE	8
BATTERY INFORMATION	10
CHARGER SPECIFICATIONS.....	10
CHARGING THE BATTERY	11
MAINTENANCE	11
DAILY CHECK LIST.....	11
INSPECTION AND CLEANING	12
STRAP INSPECTION	12
HANDLING AND STORAGE	12
BATTERY REPLACEMENT	12
ANNUAL INSPECTION	13
STRAP REPLACEMENT.....	13
DRUM REPLACEMENT	15
LIMIT SWITCH REPLACEMENT.....	16
LIMIT SWITCH ROD REPLACEMENT	17
SSRS BLOCK REPLACEMENT	18
MICA REPLACEMENT	22
CIRCUIT BOARD REPLACEMENT	22
TOUCH PAD MEMBRANE REPLACEMENT.....	24
MAINTENANCE INSPECTION CHECKLIST	26
TROUBLESHOOTING	27
ACCESSORIES	29

INTRODUCTION

How to use this Manual



DO NOT ATTEMPT TO USE THIS EQUIPMENT WITHOUT UNDERSTANDING THIS MANUAL.

To ensure safe operation, read carefully the entire manual, especially the section on “Safety Instructions and Warnings”, before installing, operating, or servicing this equipment.

If anything is not completely understood, please contact your supplier for more details. Failure to comply with warnings in this manual may result in injury.

Keep this manual with the lift and refer to it as required. Contents of this manual are subject to change without prior notice to users.

Throughout this manual, the following symbols may appear. Pay particular attention to the information provided under these headings. These special annotations are easily recognized as follows:



WARNING: this symbol is intended to alert the user to hazards or unsafe practices which could result in serious bodily harm.



CAUTION: this symbol is intended to alert the user of the presence of important operating and maintenance instructions, which could prevent product damage or possible personal injury.



NOTE: this symbol offers helpful information concerning certain operating procedures.

Additional copies of this manual can be purchased by contacting your supplier. Include the User Manual product number and equipment identification numbers.

Exploded view and parts list are available upon request.

Equipment Identification

The unit's identification number (specification, model, serial number) appears on a silver nameplate attached to the back of base.

Receipt of Equipment

Upon receipt of the equipment, verify it against the packing list to ensure it is complete and inspect the equipment for possible damage due to shipping. If there is any damage, DO NOT USE the equipment and notify the carrier immediately to file a claim. Provide complete information concerning damage claims or shipping errors to your supplier. Include all equipment identification numbers and group part numbers (if any) as described above along with a full description of damaged parts.

Key to Symbols

THE FOLLOWING SYMBOLS ARE USED ON LIFTER'S ATTACHMENT LABELS:



This symbol is required to be displayed on regulated products for sale in the European Market. It indicates that the product complies with applicable European Directives related to health, safety, environment and consumer protection.



Safe Working Load represents the maximum load the lifter is rated for safe operation.



The following symbols are used on sling labels and related to washing instructions:
Maximum washing temperature 80°C (176°F) permanent cycle.



Do not use bleach.



Do not dry clean.



Tumble dry low temperature.



Do not iron.

Please refer to individual sling labels for complete instructions regarding washing and drying.

SAFETY INSTRUCTIONS AND WARNINGS

A. GENERAL

- **IMPORTANT – READ THESE INSTRUCTIONS CAREFULLY OR SERIOUS INJURY MAY RESULT.**
- **KEEP THESE INSTRUCTIONS AND THE KEY PROVIDED WITH THE LIFT AT ALL TIMES.**
- **READ OPERATION AND MAINTENANCE INSTRUCTIONS IN THIS MANUAL BEFORE INSTALLING, OPERATING, OR SERVICING THIS EQUIPMENT.**
- **ArjoHuntleigh ceiling lifts are installed by an authorized contractor or installer**
- **Your lift is for transferring patients only. Do not use the lift for any other purpose.**
- **Always carry out the daily checklist before using the lift.**
- **ArjoHuntleigh ceiling lifts are specifically designed for ArjoHuntleigh ceiling track systems, slings and accessories. Slings and accessories designed by any other manufacturer are prohibited and will void ArjoHuntleigh’s warranty. Use only ArjoHuntleigh slings and accessories to maintain patient’s safety and product utility.**
- **ArjoHuntleigh ceiling lifts are intended to be used for patients within the specified weight limit indicated for the lift. Do not attempt to lift more than the weight limit indicated.**
- **Before attempting to transfer, the patient must be assessed by a qualified professional.**
- **ArjoHuntleigh ceiling lifts must be used by a caregiver with proper training to work with the patient to be transferred.**
- **ONLY trained and qualified caregivers should transfer a patient. DO NOT attempt to use the lift if you have not been properly trained to do so. This patient lift should never be used by a patient on his/her own.**
- **ALWAYS be prepared before attempting to transfer a patient.**
- **DO NOT use a sling that is not recommended for the lift.**
- **NEVER use a damaged, torn or frayed sling.**
- **Always place the sling around the patient according to the instructions enclosed.**
- **FOLLOW lifting procedures outlined in this manual.**
- **USE all controls and safety features only according to the rules specified in this manual. Never attempt to force a control or button on the lift.**
- **DO NOT store the charger in a shower, bath or other areas with high humidity.**
- **DO NOT drop the patient lift or battery. Dropping the battery or lift may cause internal damage that is not easily seen. If the lift is suspected to be damaged, contact an authorized technician for servicing.**
- **IMPORTANT: Keep all components of the lift clean and dry, and have electrical and mechanical safety checkpoints done as instructed in the Maintenance section of this manual.**
- **Replace any precautionary or instruction labels that cannot be easily read.**
- **Avoid violent shock during transportation.**

B. SHOCK PREVENTION

- **DO NOT touch or use a lift with bare conductors or a damaged power cord. Electrically live equipment can electrocute a patient. If the lift or charger has any exposed or damaged wires contact your local dealer immediately.**
- **DO NOT cut or remove the round grounding prong from any plug. All ARJOHUNTLEIGH lifts are equipped with three-prong plugs to protect from shock hazard or electrocution. Any two-prong electrical outlet must be replaced with a properly grounded three-prong outlet according to the National Electrical Code and local codes. It is the responsibility of the customer to have the work done by a qualified electrician.**
- **Do not splash or expose electric parts of the device to water or moisture.**
- **Check nameplate for voltage and cycle requirements. These requirements differ by country.**

SAFETY INSTRUCTIONS AND WARNINGS

Do not attempt to use the lift in an area that has a different voltage and cycle requirement.

- **DO NOT** attempt to expose service or repair the lift, battery or charger. If any unit is malfunctioning, contact your local dealer.
- **READ** the battery and charger instructions thoroughly before using or storing them.

C. FIRE AND EXPLOSION PREVENTION

- Batteries may explode, leak and cause personal injury if not disposed of properly.
 - Do not place or store the battery under direct sunlight or near a heat source
 - Do not dispose of in fire
 - Do not short the battery terminals
 - Do not incinerate
 - Flush with water if electrolyte (Acid) comes in contact with skin or eyes.
- Batteries must be recycled, disposed of according to local law regulations. When returning batteries, insulate their terminals with adhesive tape, etc. Otherwise, the residual electricity in used batteries may cause fire or explosion.



D. EQUIPMENT WARNING LABELS

- Inspect all precautionary labels on the equipment. Order and replace all labels that cannot be easily read.

DESCRIPTION OF EQUIPMENT

Lift Unit

The lift unit is an aluminium frame based system driven by a gear reduced high torque motor.

OPERATING FEATURES

- Ultra-light: 5.45 kg (12 lb), battery included.
- Electronic soft-start and soft-stop motor control.
- Easily accessible controls on both sides of the unit.
- Manual emergency lowering device (in case of electrical failure).
- Emergency brake (in case of mechanical failure). Operates on the same principle as a car safety belt mechanism.
- *Quick-Release* feature allows very fast winding and unwinding of the strap before and after transfer operation.
- *Anti-crush* feature stops the lift when there is no tension on the strap, avoiding any injury to the patient. This feature also prevents the strap from getting twisted inside the machine.
- Current limiter for circuit protection in case of overload.
- Low battery disconnect system to protect batteries from been drained.
- Lifting speed: 4 cm/sec. (1.6 in./sec.).
- Strap length up to 2.2 m (88 in). Tested for 907 kg (2000 lb).
- CSA No. 601.1, UL No. 2601-1 and CE certifications.
- Respects EMI standards.

What's included

ITEM	QTY
Voyager lift	1
Battery	1
Charger and Charge Monitor	1
Power cord	1
4 mm Allen key	1
Instruction manual	1

Parts Description

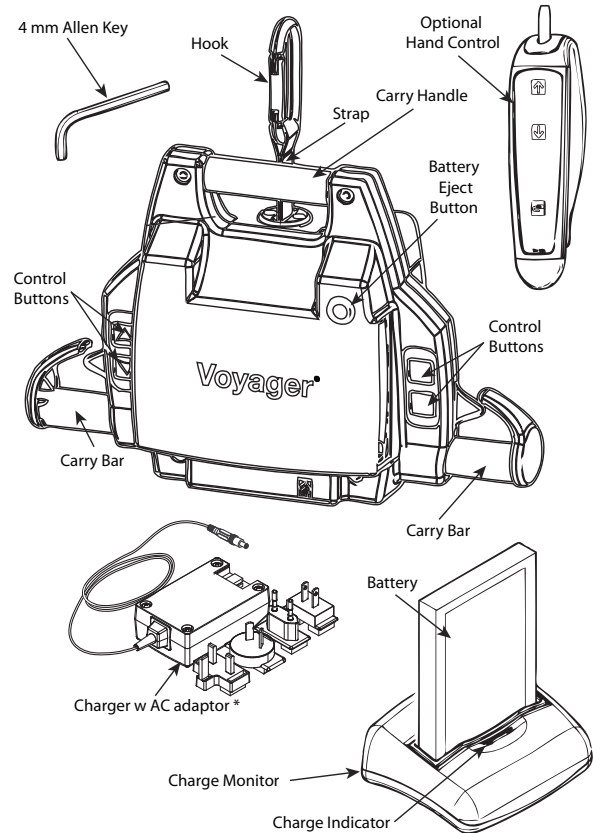

* Charger and adaptor's appearance may differ depending on unit revision.

Dimension

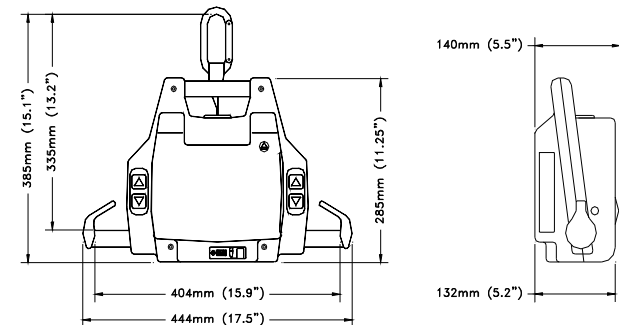

OPERATION

How to use the Voyager Portable

 **READ "SAFETY INSTRUCTIONS AND WARNINGS" BEFORE ATTEMPTING TO USE THE VOYAGER LIFT.**

Always carry out the daily checklist before each lift use.

 **Damage to the lift may occur if not properly handled. Carry the VOYAGER PORTABLE by its handle only. Do not carry the lift with the arm extension accessory or other accessory not intended to be used to carry the lift.**

1. Install the patient sling.
2. Take the battery out of the charger and insert it into the lift. Make sure the silver contact points go inside the lift.
3. Once the patient sling is installed, unwind the strap.

There are two ways to unwind the strap:

First, you can press the  button while holding tension on the strap with the other hand (there must be tension on the strap for the lift to function).

The other way to do this is to use the "QUICK-RELEASE"; Push the knob (1) and pull the strap out of the lift (2).

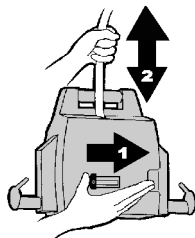



 **Push knob completely over to ensure the QUICK-RELEASE will work properly.**

 **QUICK-RELEASE will not work if there is tension on the strap. Make sure the strap has some slack in it before attempting to slide the knob over.**

DO NOT force the knob. It should slide easily.

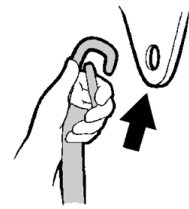
4. Attach the round hook to the trolley in the track.



 To help you reach the trolley, use the arm extension as follows:

Insert the round hook into the loop of the arm extension #700.08310 (1), then hook it to the trolley in the track (2).

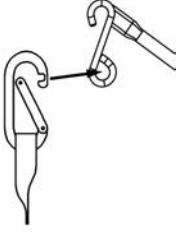
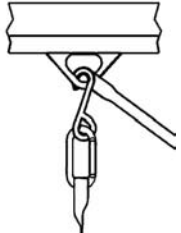
(1)  (2) 

5. Move the lift over to the patient.

 **Hold the lift with one hand at all times when near a patient.**

6. Lower the lift below the chin before beginning to attach the sling straps (this is to avoid the risk of facial contact caused by movement of the lift).

For a patient in a lying position, lower the lift near the thorax, and then install the straps.

7. Attach the straps of the sling for the sling to be used.
8. Lift the patient slightly by pressing the  button.

 **BEFORE LIFTING THE PATIENT:**

1. Make sure that all straps are attached to the carry bar.
2. Make sure the patient's arms are safely out of the way.
3. Make sure the sling is not caught on an obstruction (wheelchair brake or arm of chair).

If any of the above occurs – lower the patient immediately and correct the problem.

9. Lift until the patient's buttock clears the arm supports or the top of the bath or bed before moving the patient. Guide the legs past any obstacle.
10. When the patient is located above the desired point of transfer and ready to be lowered, press the  button.
11. Use the handles on the back of the sling to position the patient when transferring into a chair. Hold the handles firmly as the sling lowers and the sling will tilt back to position the patient.
12. Once the patient is properly seated and the straps are loose, remove the sling from the lift.

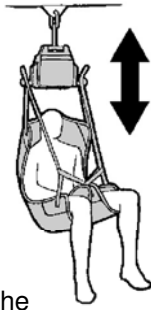

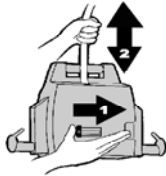

 **Hold the lift with one hand at all times when near a patient.**

13. Slide the lift away from the patient.
14. Unhook the lift from the trolley in the track and use the "QUICK RELEASE" to shorten the strap. To do so, push the knob (1) and hold the strap while it winds itself into the lift.



 **Push the knob completely over to ensure the "QUICK-RELEASE" will work properly.**

 **"QUICK-RELEASE" will not work if there is tension on the strap. Make sure the strap has some slack in it before attempting to slide the knob over.**
DO NOT force the knob. It should slide easily.

 **When using the "QUICK-RELEASE" hold the strap in your hand and release the knob (1) only when the strap is not going in motion. This will prevent wear of the internal components.**

15. The sling may be removed from around the patient.

Emergency Lowering Feature

In the event of an electrical or functional failure, the Voyager Portable has an emergency manual-lowering feature.

If the lift malfunctions when a patient is being transferred, the emergency manual lowering device provides a safe way of lowering the patient onto a chair or bed.

To operate the emergency lowering feature:

1. Find the rubber stopper and label on the side of the lift.



2. Pull the rubber stopper out of the Voyager Portable casing – **DO NOT DISCARD**.
3. Move the patient over a bed or chair.
4. Using the Allen key provided with this manual, turn the key clockwise to lower the patient into the chair. As the key turns the motor directly, each key turn will move the patient slightly.



5. Once the patient is lowered safely into a chair or bed, take the lift to a certified technician to be serviced.

Battery Information



DO NOT DROP BATTERY. A DROPPED BATTERY MAY HAVE INTERNAL DAMAGE THAT IS NOT VISIBLE. IT MAY LOSE ITS ABILITY TO RECHARGE.

Due to internal damage caused when the battery is dropped, the battery may indicate that it is fully charged, when in fact the battery cannot hold a full charge. A green light indicated on the charger may not accurately reflect a full charge on a damaged battery.

NEVER attempt to use a battery that appears to be damaged or dented.

DO NOT store battery near a heat source. Heat will damage the battery.

Always keep metal battery contacts clean.

- 24 Vdc, 2.0 Ah interchangeable and rechargeable battery.
- Provides 10 to 30 transfers per battery charge (may vary depending on patient weight and battery condition. See graph below).

Life cycle (number of charging cycles) of the battery is largely dependent on the depth of discharge in each cycle. The more the battery is drained, the shorter its life's span. The life of the battery is also related to such factors as varying temperatures and rest periods between charge and discharge.

Graph 1: Number of recharge vs. Depth of discharge

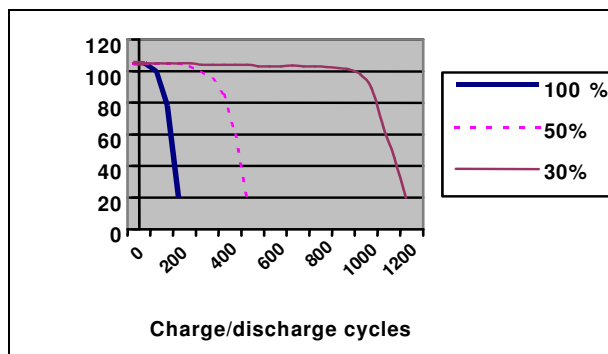

GRAPH #1 illustrates the relationship between discharging depth and expected battery life.

If you use only 30% of the battery power between each charge, you can expect the battery to fully charge 1050 times.

If you drain the battery until it beeps every time, you can expect the battery to fully charge only 300 times.



To prolong battery life - Put the battery into the charger WHENEVER THE LIFT IS NOT IN USE.

The battery will not overcharge.

ARJOHUNTLEIGH uses sealed lead-acid batteries. Contrary to nickel-cadmium, ARJOHUNTLEIGH batteries do not have any memory effect. Therefore, batteries should not be completely drained before recharge.

Graph 2: Number of lifts vs. Lift load

The graph above (GRAPH #2) illustrates the

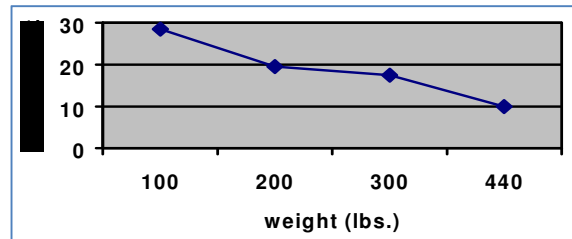

relationship between the load lifted and the number of lifts that can be done with one recharged battery.



Do not drain the battery excessively. This will dramatically reduce the battery life's span.

If the low battery buzzer sounds, be sure to recharge the battery as soon as possible.

Charger Specifications

#700.13500

- Class 2 power cord rated at 2.5 A (100-240 Vac 50-60 Hz).
- Charger input: 100-240 Vac, 50-60 Hz, 50VA
- Charger output: 27 Vdc 1A.



#700-24201

- Class 2 double insulated
- Charger input: 100-240 Vac, 50-60 Hz
- Charger output: 28.1 Vdc, 1A.
- Used with charge monitor #700-13501

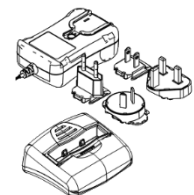

#700-15567

- Class 2 double insulated
- Charger input: 100-240Vac, 50-60 Hz
- Charger output: 24Vdc, 24VA, 1A
- Used with charge monitor #700-13501

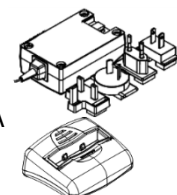

Charging the Battery

Check to make sure the green light on the charger is illuminated. This indicates that the charger is on.

- Insert the battery into the charger with the silver contact points of the battery going into the charger.
- The charging indicator light will flash yellow while the battery is charging. If the battery is fully charged, the charging indicator light will illuminate solid yellow.
- If the battery is completely depleted, it will take up to 6 hours to recharge.
- If the battery is low, it will take approximately 2 hours for a full charge.



Whenever possible, leave the battery in the charger when the lift is not in use.

At minimum, charge the battery until the light is solid yellow (not flashing) before using again. This will extend the life of the battery.

- When the lift is needed again, pull the battery out of the charger and, gently slide it back into the Voyager Portable lift. The silver contacts should be inside the lift.
- The charger can remain plugged into the wall indefinitely, convenient for overnight recharging.
- The battery can be left in the charger for an extended period of time without damaging either the charger or battery.
- If the green light does not go on when the charger is plugged into an electrical outlet, see “Troubleshooting” section.

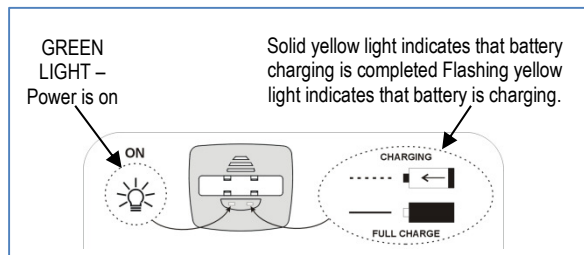

MAINTENANCE



ALWAYS CARRY OUT THE DAILY CHECKLIST BEFORE EACH LIFT USE.

DO NOT attempt to open the VOYAGER PORTABLE. Only a certified technician is authorized to open the VOYAGER PORTABLE.

Alterations made to the VOYAGER PORTABLE by someone other than a certified technician may cause serious injury.

VOYAGER PORTABLE and accessories must be inspected ANNUALLY by a certified technician in addition to the daily and other periodic visual checks done by the user specified in this section.

Preventive maintenance specified in this manual can prevent accidents and reduce repair costs.

Daily Check List

THE FOLLOWING PROCEDURE MUST BE FOLLOWED BEFORE EACH USE.

- Has the battery been charged? Charge the battery whenever the lift is not in use.
- Inspect the battery before placing it in the Voyager portable. If the battery appears to have any damage – DO NOT USE IT. Replace the battery immediately.
- Inspect the lift for any damage. If the lift casing does not look properly aligned, or there are any cracks or other damage on the lift, or any parts are missing - DO NOT USE IT. Contact your local representative to have the lift serviced.
- Attach the lift to the trolley in the track. Inspect the visible strap for any signs of wear, frays, loose threads or other damage. If there is any evidence of damage- DO NOT USE IT. Contact your local representative to have the lift serviced.
- Inspect the sling for tear, frayed straps or loose stitching. If the sling has any of the above damage –DO NOT USE IT. Contact your local representative to have the sling replaced or repaired.
- Inspect the arm extension and the adjustable extension strap (if you have these options) for wear. Check the adjustable extension strap for frays or loose stitching. Check the arm extension for damage in the metal hook or handle. DO NOT USE if there is any damage.
- Inspect the hook at the top of the strap to ensure it is properly attached and there is no damage to the hook.

Inspection and Cleaning

Clean the VOYAGER body with a dry soft cloth, or a soft cloth lightly moistened with a mild detergent solution. Do not use any type of solvent that may damage the finish.



To ensure a better rolling surface for the trolley wheels, clean the inside of the track every 4 months. To do so, insert a damp cloth in the opening and slide it from one end of the track to the other.

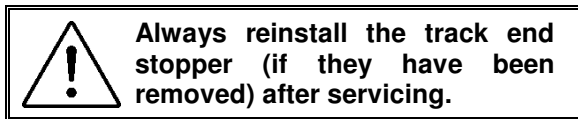

Strap Inspection

This equipment is built with a strap that can withstand a load of 907 kg (2000 lb) Nonetheless, if this strap is damaged or shows signs of wear the acceptable load on the strap before rupture can drop rapidly and present a danger for the patient or caregiver.

ArjoHuntleigh recommends thoroughly inspecting the strap every 2 months as follows:

1. Completely unwind the strap.
2. Look for any signs of wear.

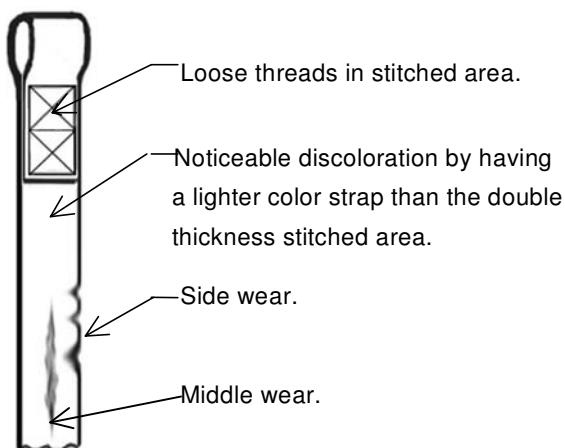

If there are any signs of wear as indicated here or other visual defects, strap should be changed immediately. By continuing to use the lift without changing the strap, caregiver and patient safety is greatly compromised.

In any case, the manufacturer recommends changing the strap at least every two years. By continuing to use the lift without changing the strap, caregiver and patient safety is greatly compromised.

Handling and Storage

Avoid violent shock during transportation.

The lift should not remain stored for long periods of time without recharging the batteries.



ArjoHuntleigh recommends charging of batteries at least every two weeks even if the lift is not used. This will prevent premature aging of batteries.

Battery Replacement

ARJOHUNTLEIGH uses sealed lead-acid batteries. Contrary to nickel-cadmium, ARJOHUNTLEIGH batteries do not have any memory effect. Therefore, batteries should not be completely drained before recharge.

Replace the battery when it has been dropped or if there is a noticeable reduction in the number of transfers that can be performed between charges. If you notice the Voyager Portable is 'beeping', see the instructions in 'Troubleshooting' section to ensure it is a problem with the battery.

To replace a battery, contact your local dealer or representative.



DO NOT ATTEMPT TO USE A BATTERY NOT AUTHORIZED BY ARJOHUNTLEIGH.

ARJOHUNTLEIGH batteries are specially designed for ARJOHUNTLEIGH charging systems. Attempting to use an unauthorized battery may seriously damage the lift and/or the charger.

Annual Inspection

The Voyager Portable and its accessories must be inspected annually by a certified technician.



VOYAGER PORTABLE AND ACCESSORIES MUST BE SERVICED EVERY 12 MONTHS AS A MINIMUM REQUIREMENT.

Do not attempt to do the inspection unless you are certified to do so.

As part of the annual inspection, an annual load test with the safe working load must be performed on the VOYAGER PORTABLE as required for CE MARK MAINTENANCE.

Strap replacement

1. Stand up the VOYAGER on a solid table. Remove the hook. Remove the strap guide by unscrewing the 2 screws.



2. Put the VOYAGER on the back and unscrew the 2 screws on the carry handle and the 2 screws at the bottom of the device.



3. Flip the VOYAGER and put it on its front. Unscrew the *Quick Release* button, the 4 screws on the cab and the 2 screws on the carry handle.

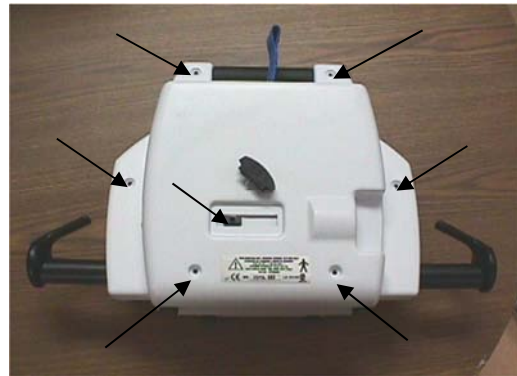

Gently, remove the rear cab from the Voyager. Just lift enough the frame from the front cab to unplug the 2 control switch connectors from the circuit board. Stand up the frame on a solid surface. Be careful with the circuit board under the frame.

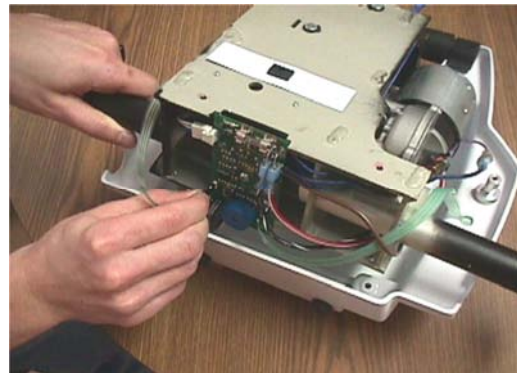

4. Temporarily screw the *Quick Release* knob and with one hand activate the *Quick Release* and with the other pull out the entire strap from the drum.



Look at the two holes on the frame (battery side) and align the two bolts of the drum by turning the drum.



5. Unscrew the long bolt from the drum.



Activate the Quick Release and pull the strap just enough to make half turn to the drum and align the other screw with the first hole of the frame. Be sure the Quick Release is in correctly. Unscrew the drum bolt and remove the strap.

6. Install the strap in the drum (loop outside) and screw the first bolt through the strap to the drum.

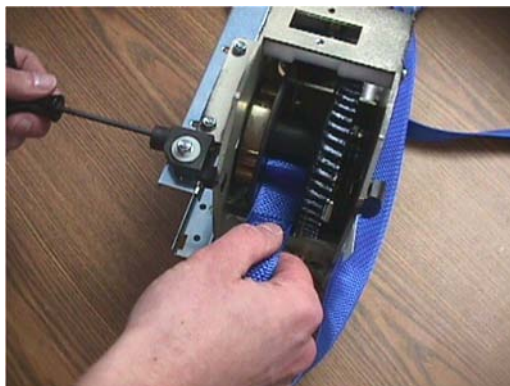

Make half turn to the drum and screw the other bolt to the drum.

Insert the other end of strap through the limit switch hole. With one hand insert the end of strap and with the other hand one finger push the limit switch and another finger guide the strap through the hole.



Pull out the entire strap from the frame. Hold the end of strap, activate the *Quick Release* and let the entire strap roll on the drum.

7. Unscrew the Quick Release button. Gently put the frame in the front cab just enough to plug the 2 control switches like **step 3**. Place the carry handle in the front cab. Place the rear cab and screw a few thread of all 6 screws front the rear cab. Tighten the *Quick Release* button.
8. Flip the Voyager. Unscrew a few threads of all the 4 screws from the front cab. Install the strap guide and screw it. Align the cab and tight the 4 carry handle screws. Tighten the 2 center screws from the rear cab.

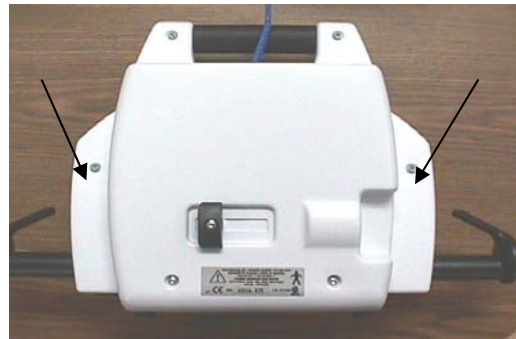

9. Flip the Voyager to the front. Screw the 2 screws at the bottom of the cab. Verify the eject battery button for working properly.



10. Stand up the Voyager. Pull on the strap and verify the *Quick Release* for proper operation.
11. Tighten both screws one after the other while checking the *Quick Release* to make

sure it is not stuck. If stuck, unscrew a little until *Quick Release* is functional.

Drum Replacement

1. Do step 1 to 3 from the **strap replacement** instructions.
2. Rewind the entire strap on the drum and fix it with tape. Temporarily screw the *Quick Release* knob. Activate the *Quick Release* with one hand and with the other slow the drum to permit to remove the 4 turns of pre-load until you place in front of you the spring screw.



3. Unscrew the spring screw just enough to loosen the spring. With a pair of pliers, grab the spring and locate it on the frame wall as shown.

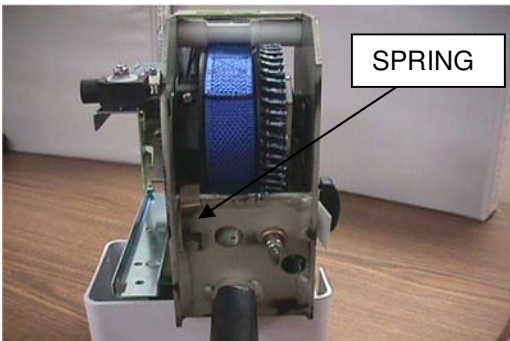
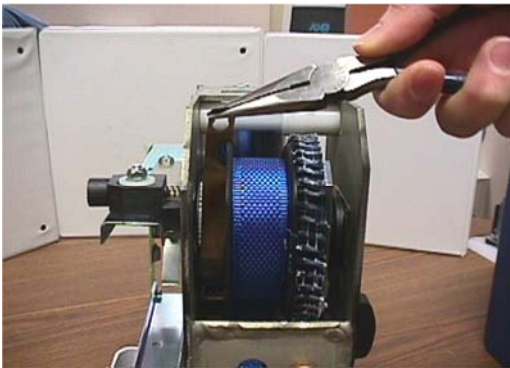

4. Remove the circlip on the center shaft of drum and pull out the shaft through the frame.

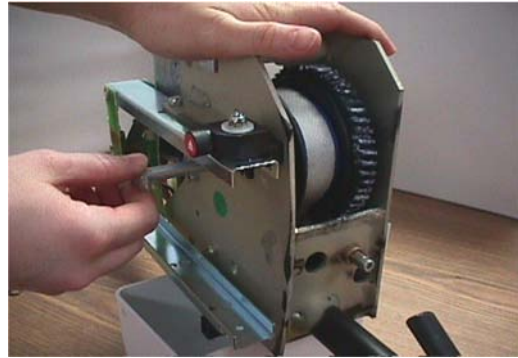

5. Pull out the drum from the frame. Be careful not to loose any parts.



6. Unscrew the spring screw on the former drum and fix it to the new one, just a few threads. Install the new drum. Hold the washer and spring to the drum with a screwdriver or home knife and insert the drum in the frame. You may have to push on the "Quick Release" button.

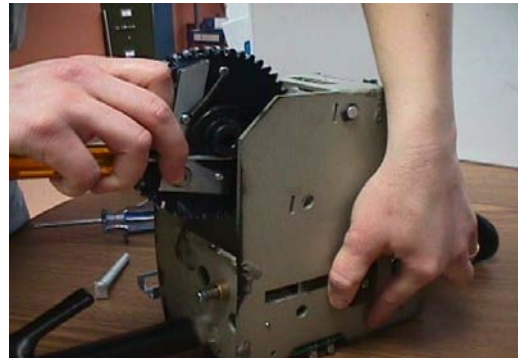

7. Reinstall the center shaft trough the frame and lock with the clip. With a pair of pliers grab the spring and locate it on the screw to the frame. Tighten the spring screw.
8. Activate the *Quick Release* button with one hand and with the other turn the drum to permit to put the 4 turns of pre-load until you place in front of you the strap end and pass the strap through the limit switch hole.
9. Unscrew the Quick Release button. Gently put the frame in the front cab just enough to plug the 2 control switches like **step 3**.
10. Place the carry handle in the front cab. Place the rear cab and screw a few threads of all

6 screws in front the rear cab. Tighten the *Quick Release* button.

11. Flip the Voyager. Unscrew a few threads of all the 4 screws from the front cab. Install the strap guide and screw it. Align the cab and tight the 4 carry handle screws. Tighten the 2 center screws from the rear cab.

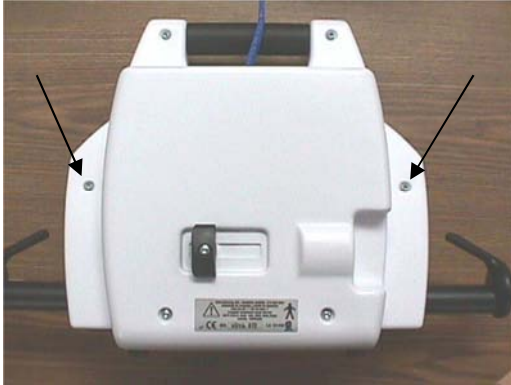

12. Flip the voyager to the front. Screw the 2 screws at the bottom of the cab. Verify the eject battery button for working properly.



Limit Switch Replacement

1. Stand up the Voyager on a solid table. Remove the Hook and remove the strap guide by unscrewing the 2 screws.



2. Put the Voyager on the back and unscrew the 2 screws on the carry handle and the 2 screws at the bottom of the device.



3. Flip the Voyager and unscrew the *Quick Release* button, the 4 screws on the cab and the 2 screws on the carry handle.
4. Stand up the Voyager. Pull on the strap and verify the *Quick Release* for proper operation.
5. Tighten both screws one after the other while checking the *Quick Release* to make sure it is not stuck. If stuck, unscrew a little until *Quick Release* is functional.

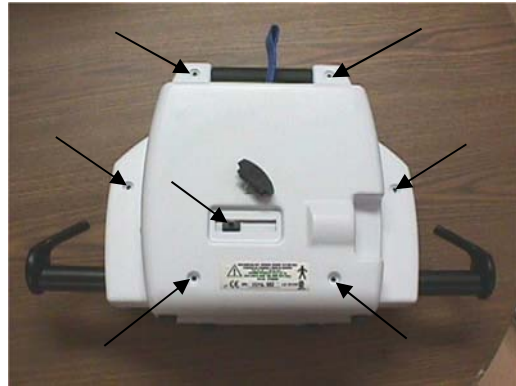

6. Gently, remove the rear cab from the Voyager. Just lift enough the frame from the front cab to unplug the 2 control switches connector from the circuit board. Stand up the frame on a solid surface. Be careful with the circuit board under the frame

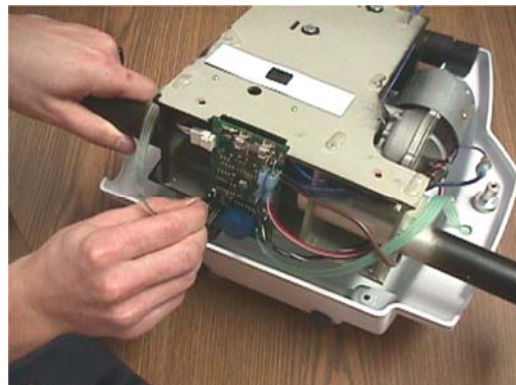

7. Unscrew the 2 screws on the limit switch with a flat tip screwdriver and the appropriate key.



8. Unplug the 2 blue wires from the limit switch.



9. Replace the limit switch by a new one and plug back the 2 blue wires on both end of the limit switch.

10. Screw back in the 2 screws on the limit switch.



11. Gently put the frame in the front cab just enough to plug back the 2 control switches to the board. Place the carry handle in the front cab. Place the rear cab and screw a few thread of all 6 screws front the rear cab. Tighten the *Quick Release* button.

12. Flip the Voyager and unscrew a few threads of all the 4 screws from the front cab. Install the strap guide and screw it. Align the cab and tight the 4 carry handle screws. Tighten the 2 center screws from the rear cab.

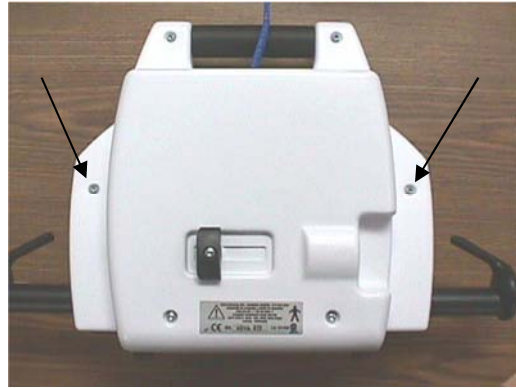

13. Flip the Voyager to the front. Screw the 2 screws at the bottom of the cab. Make sure the eject battery button is working properly.



14. Stand up the Voyager. Pull on the strap and verify the *Quick Release* for proper operation.

15. Tighten the two screws under the *Quick Release* while checking if the *Quick Release* is moving freely. If stuck, unscrew a little until the *Quick Release* is functional.

Limit Switch Rod Replacement

1. Do steps 1 to 7 from the limit switch replacement instructions.

2. Remove the spring from the limit switch rod.

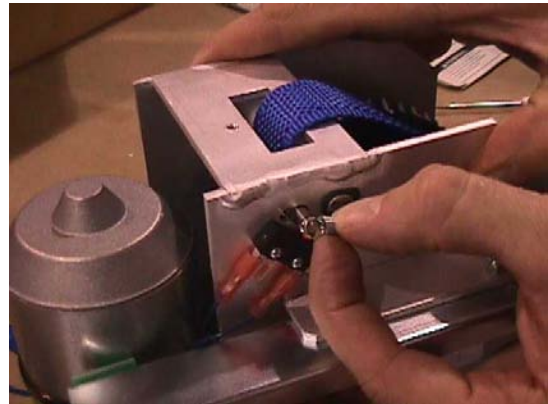

3. Drill out the rivet from the other side and remove the limit switch rod.

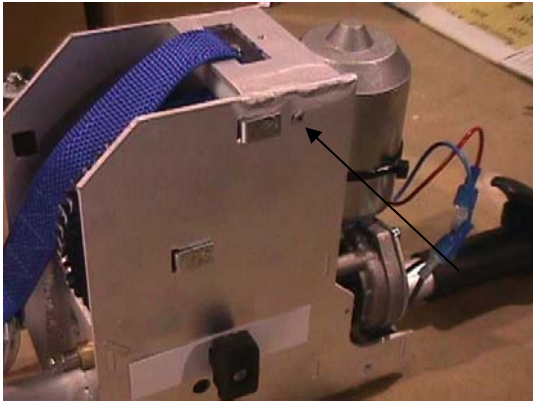

4. Insert the new rod. Insert the rivet in the rod hole and pop up the rivet.



5. Put the spring back on the limit switch rod.
6. Do steps 11 to 15 of the limit switch replacement instructions.

SSRS Block Replacement

1. Stand up the Voyager on a solid table. Remove the hook and remove the strap guide by unscrewing the 2 screws.



2. Put the Voyager on the back and unscrew the 2 screws on the carry handle and the 2 screws at the bottom of the device.



3. Flip the Voyager and unscrew the *Quick Release* button, the 4 screws on the cab and the 2 screws on the carry handle.

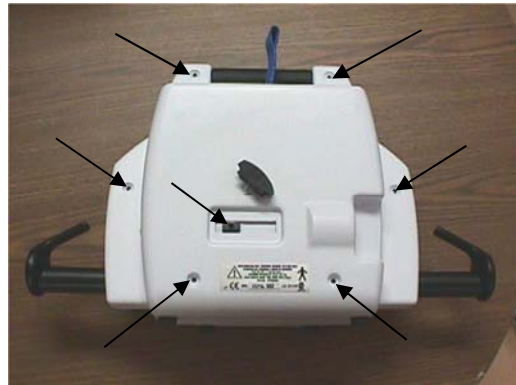

4. Gently, remove the rear cab from the Voyager. Just lift enough the frame from the front cab to unplug the 2 control switch connectors from the circuit board. Stand up the frame on a solid surface. Be careful with the circuit board under the frame.

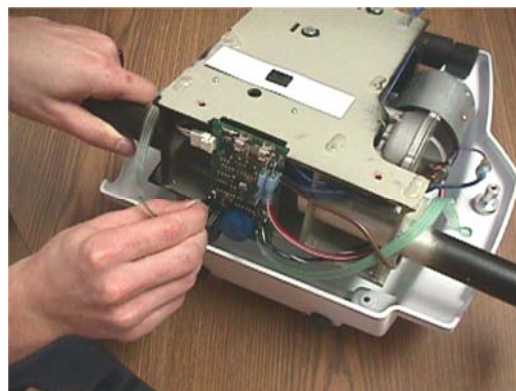

5. Unscrew the "no 25 Torx screw". The electric board does not need to be unplugged. It only needs to be removed from the frame so the SSRS block can be reach.

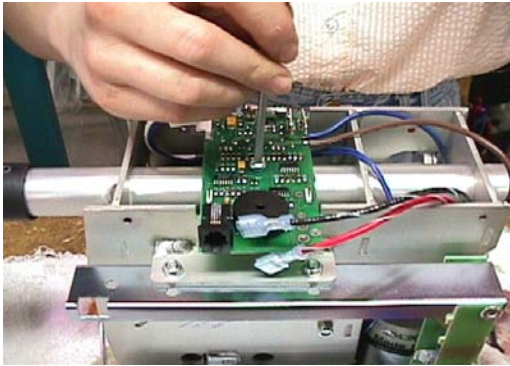

6. Unplug the blue and white wires plug.



7. Unscrew the two small limit switch bolts and remove the limit switch's board.

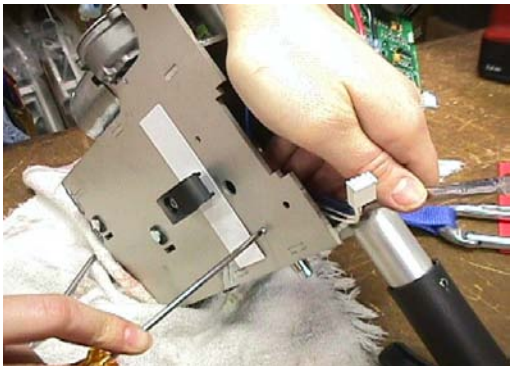

8. The next step would be to remove the drum. First, rewind the entire strap on the drum and fix it with tape. Temporarily screw the *Quick Release* knob. Activate the *Quick Release* with one hand and with the other slow the drum to permit to remove the 4 turns of pre-load until you place in front of you the spring screw.



9. Unscrew the spring screw just enough to loosen the spring. With a pair of pliers, grab the spring and locate it on the frame wall like showed.

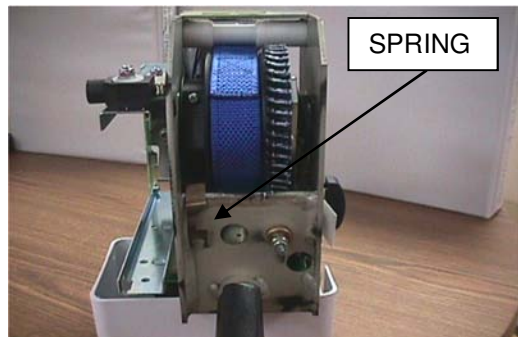
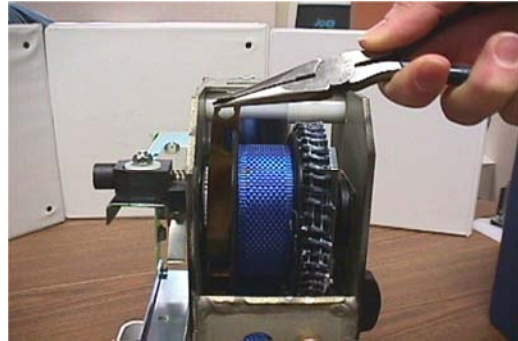

10. Remove the clip on the center shaft of drum and pull out the shaft through the frame.

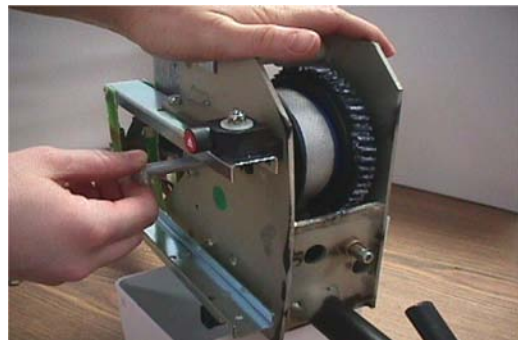

11. Pull out the drum from the frame. Be careful not to loose any parts.



12. Once the drum is removed, the next step is to pull out the electric motor. First, unplug the two wires attached to the motor.

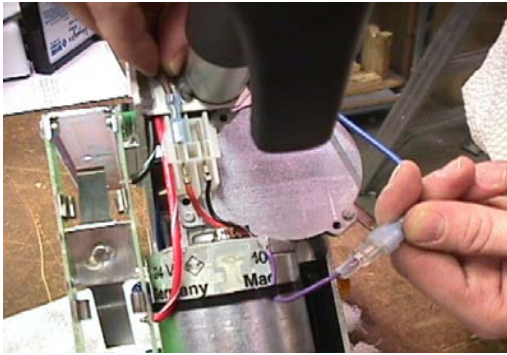

13. Unscrew the 3 motor bolts and pull it out from the frame. When you pull out the motor, make sure the shaft stay assembled with the motor. The bearing does not need to stay with the shaft.

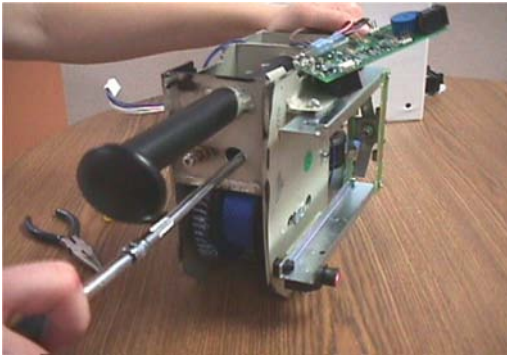

14. Uncouple the spring (1) that holds the CBLM plate (2) and unclip the SSRS bloc (3) from the CBLM plate (2). To unclip it, while holding the CBLM plate, push the block out.

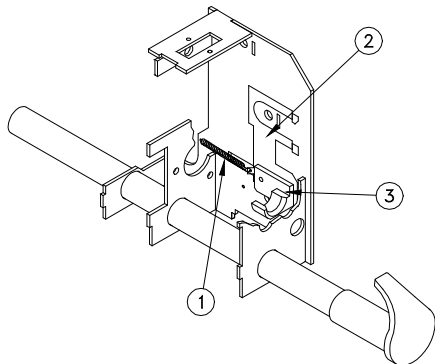

15. Replace the SSRS block and clip the new block in the slot of the CBLM plate. To clip

the block, make sure to push the plate in the bottom of the SSRS block slot.

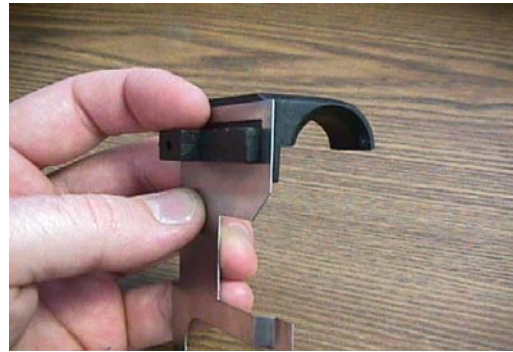

16. Put the bearing, shaft and motor in place. The bearing has to be placed between the brass bushing and the shaft with the writing on the bearing against the frame.

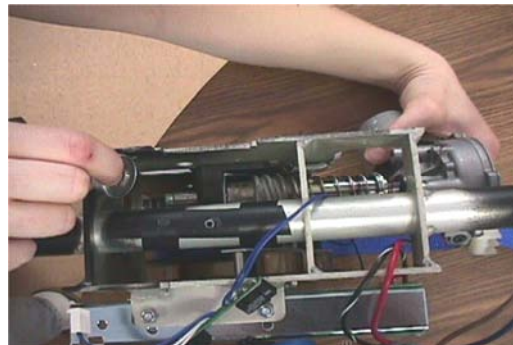

17. Reinstall the drum. Hold the washer and spring to the drum with a screwdriver or home knife and insert the drum in the frame. You may have to push on the "Quick Release" button.

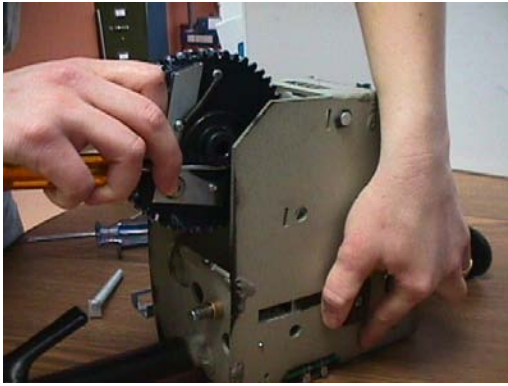

18. Reinstall the center shaft trough the frame and lock it with the clip. With a pair of pliers, grab the spring and locate it on the screw of the drum. Tighten the spring screw.



19. Activate the *Quick Release* button with one hand and with the other, turn the drum to permit to put the 4 turns of pre-load on the spring. Place the strap end in front of you, take out the tape and pass the strap through the limit switch hole.



Make sure the strap goes through the limit switch hole after being guided by the white roller as shown. If not, change the direction of rotation.

20. Screw back in the two limit switch boards. Once it is done, verify that when sliding the *Quick Release*, it activated ("click") the two limit switches.

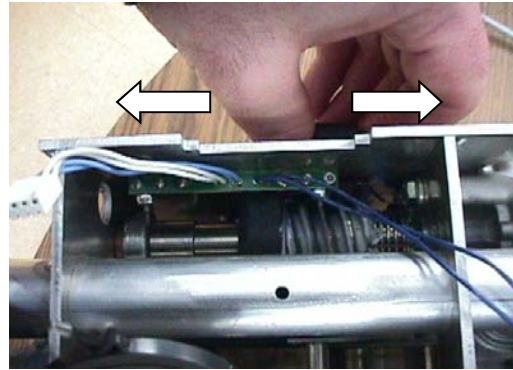

21. Screw the electric board back in place and plug the unplugged wire to it. Plug the brown wire in the red motor plug and the blue and purple wire together.
22. Gently put the frame in the front cab just enough to plug back the 2 control button connectors with the white dot mark facing the *Quick Release* (back) side. Place the carry handle in the front cab. Place the rear cab and screw a few threads of all 6 screws in front the rear cab. Tighten the *Quick Release* button.
23. Flip the Voyager and unscrew a few threads of all the 4 screws from the front cab. Install the strap guide and screw it. Align the cab and tight the 4 carry handle screws. Tighten the 2 center screws from the rear cab.

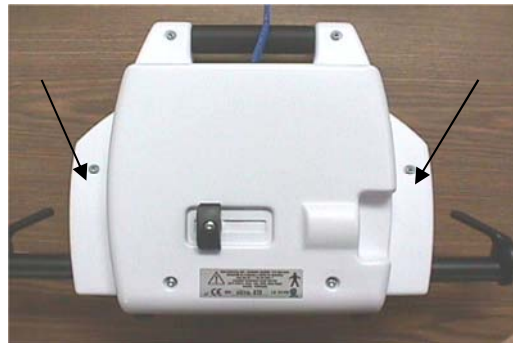

24. Flip the Voyager to the front. Screw the 2 screws at the bottom of the cab. Make sure the eject battery button is working properly.



25. Stand up the Voyager. Pull on the strap and verify the Quick Release for proper operation.
26. Tighten the two screws under the Quick Release while checking if the Quick Release is moving freely. If stuck, unscrew a little until the Quick Release is functional.

Mica Replacement

1. Stand up the Voyager on a solid table. Remove the hook and remove the strap guide by unscrewing the 2 screws.



2. Flip the Voyager and put it on its front. Unscrew the Quick Release button, the 4 screws on the cab and the 2 screws on the carry handle.

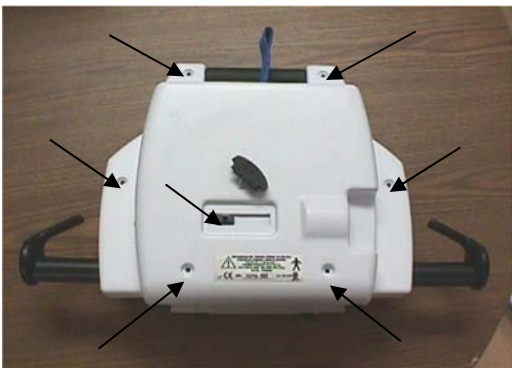

2. Gently, remove the rear cab from the Voyager. Replace the mica by the new one.

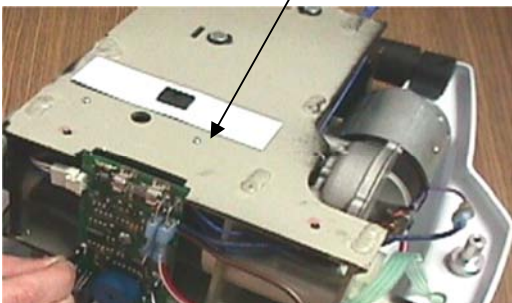

3. Place the rear cab and screw a few threads of all the 6 rear cab screws. Tight the Quick Release button.
4. Flip the Voyager and unscrew a few threads of all the 4 screws from the front cab. Install

the strap guide and screw it. Align the cab and tight the 4 carry handle screws. Tighten the 2 center screws from the rear cab.



6. Make sure the eject battery button is working properly.
7. Stand up the Voyager, pull the strap and verify the Quick Release for proper operation.
8. Tighten the two (2) screws under the Quick Release one after the other while checking if the Quick Release moves freely. If stuck, unscrew a little until Quick Release is functional.

Circuit Board Replacement

1. Stand up the Voyager on a solid table. Remove the hook and remove the strap guide by unscrewing the 2 screws.



2. Put the Voyager on the back and unscrew the 2 screws on the carry handle and the 2 screws at the bottom of the device.



3. Flip the Voyager and unscrew the Quick Release button, the 4 screws on the cab and the 2 screws on the carry handle.



4. Gently, remove the rear cab from the Voyager. Just lift enough the frame from the front cab to unplug the 2 control switch connectors from the circuit board. Remove the frame from the front cab.

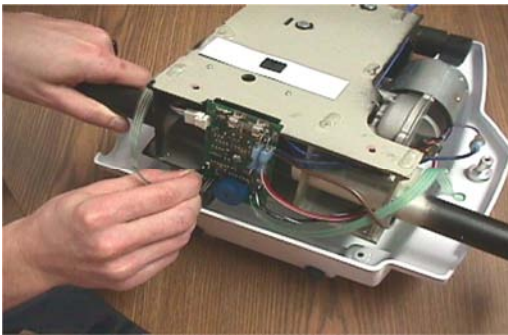

5. Unplug the red/white and the black/white wires from the board.

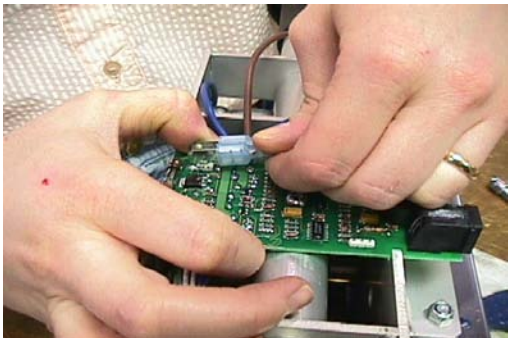

6. Unplug the blue and white wires plug.



7. Unplug the two wires (brown and blue) attached to the motor.

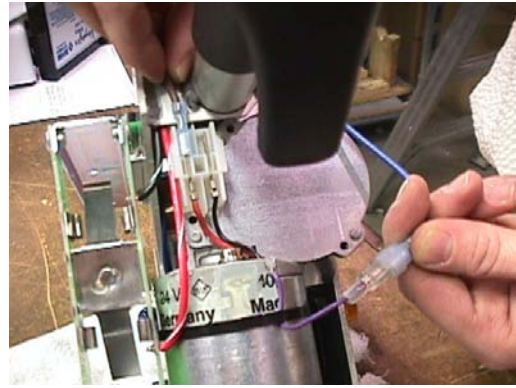

8. Unscrew the "no 20 Tork screw". To remove the electric board.

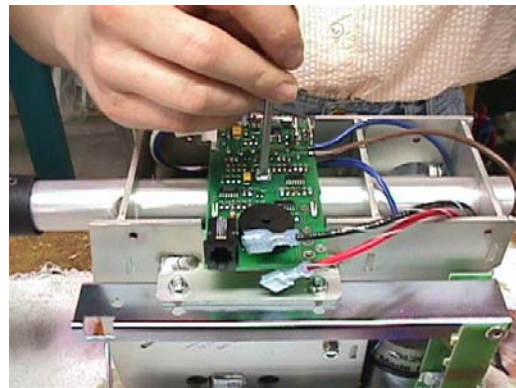

9. Screw the new electric board back in place and plug the unplugged wire to it. Plug the brown wire in the red motor plug and the blue and purple wire together.

10. Gently put the frame in the front cab just enough to plug back the 2 control button connectors with the white dot mark facing the Quick Release (back) side. Place the carry handle in the front cab. Place the rear cab and screw a few thread of all 6 screws front the rear cab. Tighten the *Quick Release* button.

11. Flip the voyager and unscrew a few threads of all the 4 screws from the front cab. Install the strap guide and screw it. Align the cab and tight the 4 carry handle screws. Tighten the 2 center screws from the rear cab.



12. Flip the Voyager to the front. Screw the 2 screws at the bottom of the cab. Make

sure the eject battery button is working properly.



13. Stand up the Voyager pull on the strap and verify the Quick Release for proper operation.
14. Tighten the two screws under the *Quick Release* while checking if the *Quick Release* is moving freely. If stuck, unscrew a little until the *Quick Release* is functional.

Touch Pad Membrane replacement

1. Put the Voyager on the back and unscrew the 2 screws on the carry handle and the 2 screws at the bottom of the device.



2. Flip the Voyager and unscrew the 2 center screws from the rear cab.



3. Flip the Voyager and gently, remove the front cab from the Voyager. Just lift enough the frame from the front cab to unplug the 2

control switch connectors from the circuit board. Be careful with the circuit board under the frame.

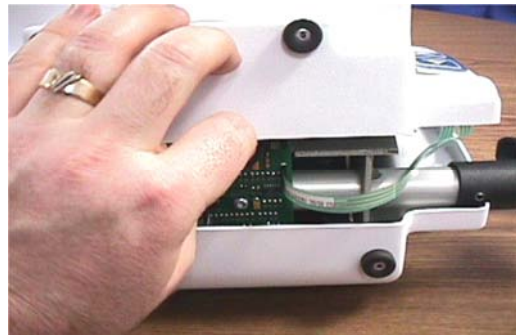

4. Remove the old membrane with a thin blade. If necessary, remove traces of adhesive with a soft solvent.



If the new membrane does not have a white dot on the connector, deposit the membrane on the back and make a white point on the right side of the connector.

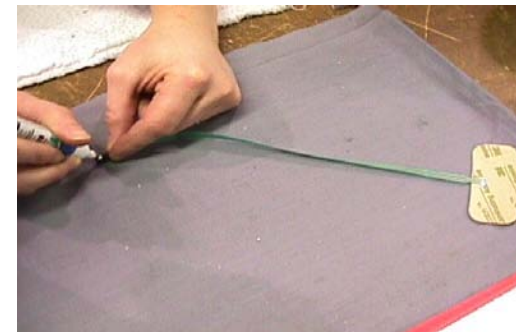

5. Replace by the new one by passing the cable in the cab hole. Peel the back of the membrane and stick it to the cab.



6. Gently put the frame in the front cab just enough to plug back the 2 control button

connectors with the white dot mark facing the Quick Release (back) side. Place the carry handle in the front cab. Place the rear cab and screw a few threads of all 6 screws front the rear cab. Tight the *Quick Release* button.

7. Flip the voyager Unscrew a few thread of all the 4 screws from the front cab. Install the strap guide and screw it. Align the cab and tight the 4 carry handle screws. Tighten the 2 center screws from the rear cab.



8. Flip the Voyager to the front. Screw the 2 screws at the bottom of the cab. Verify the eject battery button for working properly.



9. Stand up the Voyager pull on the strap and verify the Quick Release for proper operation while checking the *Quick Release* to make sure it is not stuck. If stuck, unscrew a little until *Quick Release* is functional if necessary.

MAINTENANCE INSPECTION CHECKLIST

Maintenance Inspection Checklist





TO BE INSPECTED BY USER						
ITEM	INITIALLY	BEFORE EVERY USE	EVERY 2 MONTHS	EVERY 6 MONTHS	EVERY YEAR	EVERY 2 YEARS
LIFT DEVICE						
Inspect for missing hardware or broken panel.	X	X			X	
Inspect strap for wear.		X	X			
Recharging battery.		X				
Inspect round hook on the strap of the lift for damage or cracks.					X	
Inspect trolley in track for damage, rust or cracks. Replace if damaged.					X	
Overall inspection by authorized personnel					X	
SLING AND HARDWARE						
Check all sling attachments for sign of wear.		X				
Inspect sling material for wear or deterioration.		X				
Inspect sling straps for wear.		X				
Inspect for any defect or loose threads in the "stitched areas".		X				
Cleaning sling as indicated on the tag.	<i>When Necessary</i>					
ACCESSORIES						
Verify strap extension for wear.				X		
Verify arm extension for wear.				X		

MAINTENANCE BY A CERTIFIED TECHNICIAN						
Replace strap.						X
Inspect the welding aspect on the frame to detect cracks.					X	
Inspect connecting joints for proper attachment.					X	
Verify that the emergency brake on the drum is turning freely.					X	
Verify emergency devices for good functioning.					X	

	<p>Maintenance inspection points are suggested by the manufacturer, however in certain cases, some inspections should be done on a more frequent basis. By continuing to use the lift without replacing the listed parts in this maintenance inspection checklist, caregiver and patient safety is greatly compromised.</p>
---	---

TROUBLESHOOTING

	<p>DO NOT attempt to open the VOYAGER PORTABLE. Only a certified technician is authorized to open the VOYAGER PORTABLE.</p> <p>Alterations made to the VOYAGER PORTABLE by someone other than a certified technician may cause serious injury.</p>
---	--

PROBLEMS	TO CHECK
The unit does not work when you press the  or  buttons on the handset.	<ul style="list-style-type: none"> • Make sure the handset is plugged correctly into the unit. • Use the control switches directly on the unit. If they are working, it indicates a problem with the handset; you would then need to change the handset.
The unit does not work when you press the  or  buttons on both sides of the lift.	<ul style="list-style-type: none"> • Is the battery charged and correctly installed? Ensure the battery is inserted into the lift with the silver contact points inside the lift. Place the battery into the charger and check the light on the charger. If the light remains red, leave the battery in the charger for approximately 2 hours. • Is the “QUICK RELEASE” knob completely to the left (locked) position? If not, the lift will not operate. Tighten the tension on the strap to help move the “Quick Release” knob. • Is there tension on the strap? The “Anti Crush” feature will prevent the lift from working if there is no tension. • If all of the previous points have been checked without success, you probably have a motor or electric problem; you then need to call your ArjoHuntleigh representative.
The unit starts and stops repetitively.	<ul style="list-style-type: none"> • If the load is more than safe working load, the unit will not work due to an overload protection on the motor. • Has the lift been making a “beeping” sound? The battery is low and needs to be charged.
The lift emits a “beep” during utilization. The unit may stop lifting but you can still lower it.	<ul style="list-style-type: none"> • Batteries are low, recharge them.
Battery is always dead after a few transfers (3 to 5).	<ul style="list-style-type: none"> • Replace battery with a new one, the life of the current one is probably nearly over. (See the “Battery Information” section on page 10)
The light on the charger (A8200) shows green (yellow for charger #700.1350X) when the battery is inserted, yet the lift will only do one or two transfers.	<ul style="list-style-type: none"> • Battery has either been dropped or damaged in some other way. Replace the battery.
Charger #700.1350X: Green light is not illuminated	<ul style="list-style-type: none"> • Is the charger plugged into a standard outlet? • Try plugging the charger into another outlet to see if it will work. • Contact your local dealer or representative.
Charger #700.1350X: When battery is inserted into the charger, the yellow light does not flash or illuminate solid.	<ul style="list-style-type: none"> • Check the orientation of the battery. The silver contact points should be inside the charger. • Contact your local dealer or representative.

TROUBLESHOOTING

The battery does not slide into the lift.	<ul style="list-style-type: none">• Check if there is any damage to the battery that would interfere in the lift battery's slot. IF THERE IS DAMAGE - DO NOT USE THE BATTERY.• Try to slide in another battery to see if there is any damage in the lift battery's slot. If so, call your ArjoHuntleigh representative, if not discard the damaged battery.
Cannot remove battery from the lift.	<ul style="list-style-type: none">• See "Operation" instructions "Charging the Battery" on how to remove the battery.• If the battery will not come out of the lift, tilt the lift to the side so that the battery opening is under the lift. With your hand guarding the opening for the battery, press the eject button on the front of the Voyager Portable while gently tapping the lift to help jolt the battery out of the lift. ONCE THE BATTERY IS REMOVED – DISCARD BATTERY AND REPLACE.• If you cannot remove the battery after trying the above, contact your local dealer or representative for assistance.

ACCESSORIES

BATTERY
Product No.
700-08500

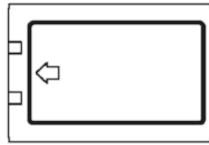

TRAVEL HAND BAG
Product No.
002.08150

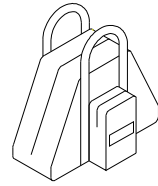

**CHARGER WITH
US/JP ADAPTOR**
Product No.
700-15561

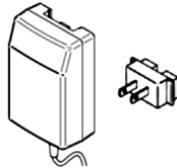

**KWIKTRAK TRACK
STOPPER**
Product No.
700.11005

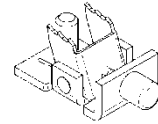

**CHARGER WITH
CE ADAPTOR**
Product No.
700-15563

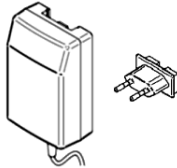

CARABINER
Product No.
000.08000

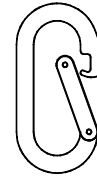

**CHARGER WITH
AU ADAPTOR**
Product No.
700-15564

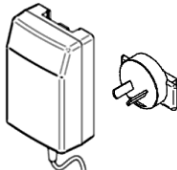

**TROLLEY FOR BHM
TRACK SYSTEM**
Product No. A5900



**CHARGER WITH
UK ADAPTOR**
Product No.
700-15566

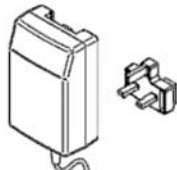

KWIKTRAK TROLLEY
Product No. 700.10650

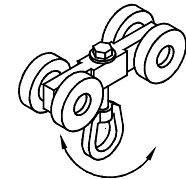

**CHARGE
MONITOR**
Product No.
700-13501



SWIVEL TROLLEY
Product No.
700.10620

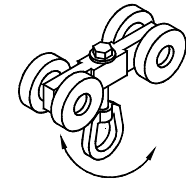

**ARM
EXTENSION**
Product No.
24": 700-08310
36": 700-08320



HANDSET
Product No.
700-13825



**EXTENSION
STRAP**
Product No.
700.03720



**SWIVEL
ADAPTOR**
Product No.
700.10950

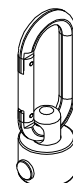

ARJOHUNTLEIGH

GETINGE GROUP

GETINGE GROUP is a leading global provider of products and systems that contribute to quality enhancement and cost efficiency within healthcare and life sciences. We operate under the three brands of **ArjoHuntleigh**, **GETINGE** and **MAQUET**. **ArjoHuntleigh** focuses on patient mobility and wound management solutions. **GETINGE** provides solutions for infection control within healthcare and contamination prevention within life sciences. **MAQUET** specializes in solutions, therapies and products for surgical interventions and intensive care.

www.ArjoHuntleigh.com

 **ArjoHuntleigh AB**
Verkstadsvägen 5
241 38 Eslöv
SWEDEN